

Air Tube Disc Clutches and Brakes

High Torque Clutches

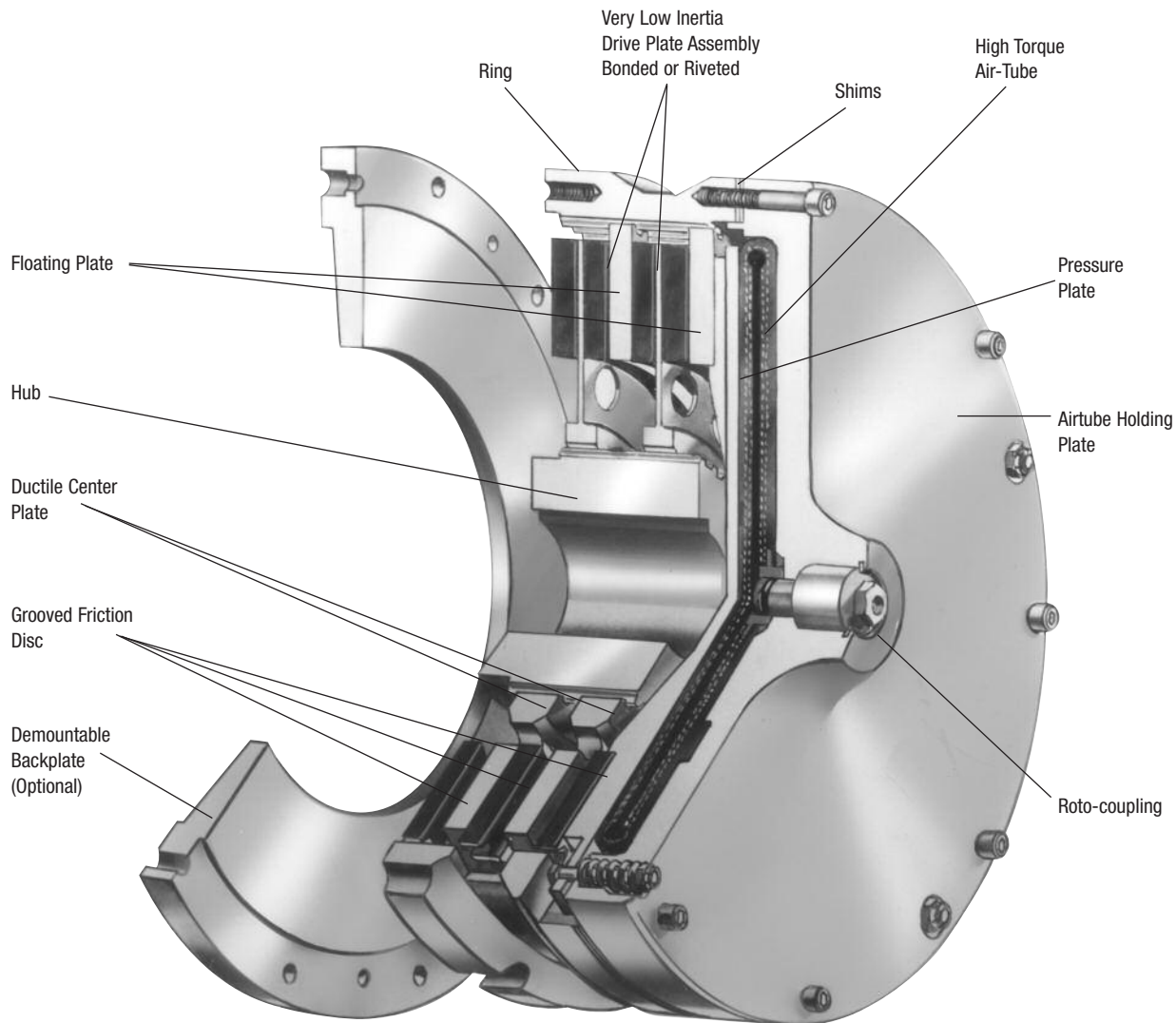

Wichita High Torque Clutches provide the highest torque to size ratios of any Wichita Clutch. They provide smooth controlled starts and stops and are designed for minimum power loss due to low rotating inertia.

- Extremely fast response
- No lubrication
- High torque to size ratio
- Low rotating inertia

Selection Requirements

To properly select a High Torque Clutch and Low Inertia Brake, the following information must be determined.

1. Torque necessary to do the work (clutch)
2. Rotating inertia to be stopped and started
3. Heat generated by each stop/start
4. Torque necessary to stop inertia (brake)
5. Shaft size

Air Tube Disc Clutches and Brakes

Selection Example

Data

Rated Tonnage As Required
 Crankshaft Speed 30 RPM
 (Continuous Run)
 Clutch-Brake Shaft RPM 204 RPM
 Crankshaft Speed 30 RPM
 Degrees of Crank to start 90°
 Degrees of Crank to stop 90°
 Connecting Rod Length = b 36 in.
 Stroke 6 in.
 1/2 of Press Stroke (throw) = a 3 in.
 WR² of Parts on Backshaft 78.2 lb.ft.²
 WR² of Parts on Crankshaft 39,091 lb.ft.²
 Material Shear Stress 45,000 PSI
 Blade Width 60 in.
 Shaft Size 4 in.
 Maximum Material to be Sheared x
 Air Pressure Available 100 PSI

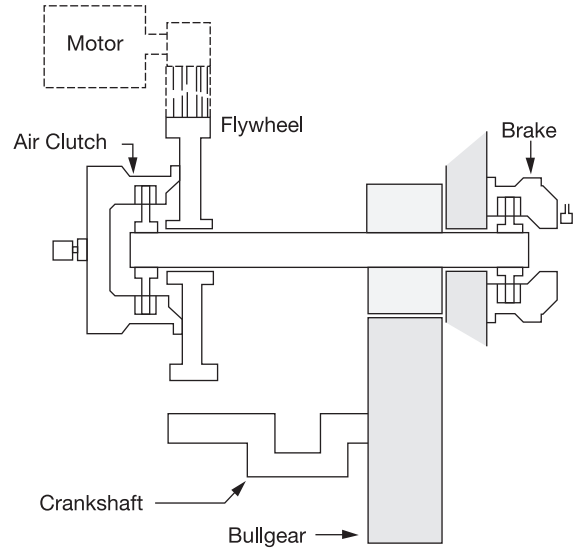

Calculations

Torque @ Crank
 = (Material Shear Stress) (x) (Blade Width) (Torque Arm)

Torque arm = y = (x) (tan α)
 c = a + b - x
 = 3 + 36 - .25
 = 38.75 in.

Cos α
 = $\frac{b^2 + c^2 - a^2}{2bc}$
 = $\frac{(36)^2 + (38.75)^2 - (3)^2}{(2)(36)(38.75)}$
 = .99948
 α = 1.8478°

Torque Arm = y = (c) (tan α)
 = (38.75) (tan 1.8478°)
 = (38.75) (.03226)
 = 1.25 in.

Torque @ Crank
 = (Material Shear Stress) (x) (Blade Width) (Torque Arm)
 = (45,000) (.25) (60) (1.25)
 = 843,750 lb.in.

Torque @ Clutch
 = (Torque @ Crank) ÷ $\frac{\text{Clutch RPM}}{\text{Crankshaft RPM}}$
 = 843,750 ÷ $\frac{204 \text{ RPM}}{30 \text{ RPM}}$
 = 124,081 lb.in.

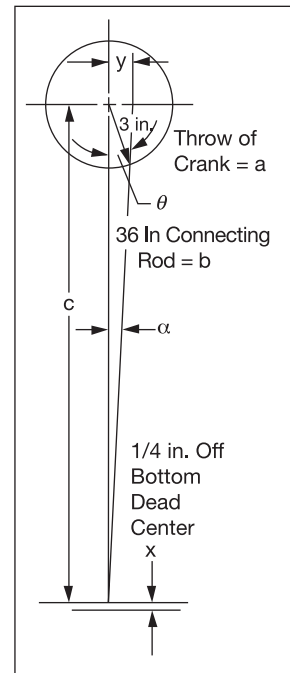

Air Tube Disc Clutches and Brakes

High Torque Clutches

Clutch Selection

Per the application factors on page 23 a "Back Geared Press is 'Group C'."

$$\frac{\text{HP}}{100 \text{ RPM}} = \frac{\text{Torque}}{630} = \frac{124,081}{630} = 197$$

The preliminary clutch selection based on 124,081 lb.in. and 197 HP/100 RPM is an ATD-224 Low Inertia High Torque Clutch. (page 48)

A Low Inertia High Torque Clutch was chosen because of the continuous duty (non-cyclic) operation having a relatively low heat HP requirement.

ATD-224 Low Inertia High Torque Clutch = 280 HP/100 RPM

Rated Torque = 480,000 lb.in @ 100 PSI

Required clutch air pressure is:

$$\text{PSI} = \frac{\text{Clutch required torque} \times (100 \text{ PSI})}{\text{Catalog rated torque @ 100 PSI}}$$

Actual required clutch PSI

$$\begin{aligned} \text{PSI} &= \frac{124,081}{480,000} \times (100 \text{ PSI}) \\ &= 26 \text{ PSI minimum is required.} \end{aligned}$$

This application has 100 PSI available.

Contact velocity of rotating disc is:

$$\begin{aligned} V_c &= \frac{(\text{Diameter of Center Plate}) (\pi) (\text{RPM})}{12 \text{ in.ft.}} \\ &= \frac{24}{12} (\pi) (204) = 1,282 \frac{\text{ft.}}{\text{min.}} \end{aligned}$$

(Ductile iron is not required, see page 23).

Maximum bore for ATD-224 High Torque Low Inertia Clutch = 7 in.

Check clutch inflation time for 90° start angle (see page 52, PSI pressure curves)

Estimated time to start

$$\begin{aligned} &= \frac{\text{Start Angle}}{360^\circ} \frac{60}{\text{Crankshaft RPM}} \\ &= \frac{90^\circ}{360^\circ} \frac{60}{30} = 0.5 \text{ sec.} \end{aligned}$$

- P_1 = Line pressure to clutch
- P_2 = Required pressure to clutch
- LN = Natural log
- k = Inflation coefficient (ATD-224 H.T. @ 100 PSI) = 2,600
- u = For ATD-224 H.T. Clutch @ 100 PSI = 2.5

Time to 26% of line pressure.

$$\begin{aligned} t &= \frac{\text{LN} \left[\frac{P_1}{P_1 - P_2} \right]^{\frac{1}{u}}}{k} \\ t &= \left[\frac{\text{LN} \left[\frac{100}{100 - 26} \right]}{2,600} \right]^{\frac{1}{2.5}} \\ &= 0.027 \text{ seconds} \end{aligned}$$

Clutch will be fully inflated at 90° of crankshaft rotation.

Clutch exhaust time @ 100 PSI = E = .078 (page 52).

Note:

This application example is for preliminary sizing only. Contact a Wichita Sales Engineer or the factory for final selection.

Low Inertia Brake Selection

To properly size a brake, the total rotating inertia reflected to the clutch and brake shaft must be known.

Alternate shaft WR²
referred to clutch shaft

$$= \frac{\text{Alternate shaft WR}^2}{39,091} \left[\frac{\text{Alternate shaft RPM}}{\text{clutch shaft RPM}} \right]^2$$

$$= \frac{845.4 \text{ lb.ft.}^2}{39,091} \left[\frac{204}{30} \right]^2$$

WR² referred to clutch-brake shaft = 845.4 lb.ft.² @204 RPM

Total inertia Back shaft WR² = 78.2 lb.ft.²

Clutch hub & drive plate WR² from Specification Table = 101.0 lb.ft.²

Estimate brake WR² (assume same as clutch) = 101.0 lb.ft.²

Total WR² referred to clutch-brake = 1,125.66 lb.ft.² (Estimated)

Estimated time to stop:

$$= \left[\frac{\text{Start Angle}}{360^\circ} \right] \left[\frac{60}{\text{Crankshaft RPM}} \right]$$

$$= \left[\frac{90^\circ}{360^\circ} \right] \left[\frac{60}{30} \right] = .5 \text{ sec.}$$

The deceleration torque is:

$$T = 12 \left[\frac{\text{WR}^2}{32.2} \right] \left[\frac{\text{Brake RPM}}{9.5(t)} \right]$$

$$= 12 \left[\frac{1125.66}{32.2} \right] \left[\frac{204}{9.5(.5)} \right]$$

Deceleration Torque = 18,015 lb.in.

The HP / 100 RPM for this application is:

$$\frac{\text{HP}}{100 \text{ RPM}} = \frac{\text{Torque (lb.in.)}}{630} = \frac{18,015}{630} = 29 \text{ HP/100 RPM}$$

Consult the Specification Table on pages 36-37 to select a brake based on torque and HP/100 RPM. Under "Duty C", an ATD-214 brake has 32 HP/100 capacity and 55,250 lb.in. torque. The rotating inertia of an ATD-214 Low Inertia Brake is 11 lb.ft.². Therefore, the actual rotating inertia reflected to brake is 1035.6 lb.ft.².

$$\text{The actual deceleration torque} = 12 \left[\frac{1035.6}{32.2} \right] \left[\frac{204}{9.5} \right]$$

$$= 16,575 \text{ lb. in.}$$

Required air pressure is:

$$\text{Brake} = \frac{\text{Brake required torque} \times (100 \text{ PSI})}{\text{Catalog rated torque @ 100 PSI}}$$

$$= \frac{16,575 \text{ lb. in.}}{55,250 \text{ lb. in.}} \times 100$$

$$= 30 \text{ PSI minimum}$$

This application has 100 PSI available.

The average heat HP each stop

$$= \frac{(\text{Brake Torque})}{63,000} \times \text{RPM} \times 1/2$$

$$= \frac{16,575}{63,000} \times 204 \times .5$$

$$= 26.8 \text{ HP}$$

$$\text{Friction area necessary to absorb heat} = \frac{\text{Heat HP}}{.7} = \frac{26.8}{.7} = 39 \text{ in.}^2$$

$$= \frac{\text{heat HP}}{\text{Absorbition rate for .5 sec. (see page 174)}}$$

An ATD-214 Low Inertia Brake has 316 in.² of friction lining available to absorb heat generated by stopping. Maximum bore for an ATD-214 Low Inertia Brake is 4-1/8 inches.

Based on the given application data and the following calculations, an ATD-224 Low Inertia High Torque Clutch and ATD-214 Low Inertia Brake have been selected as having sufficient torque and heat dissipation capacity with minimum diameter and sufficient bore capacity.

Note:

These application examples are for preliminary sizing only. Contact a Wichita Sales Engineer or the factory for final selection.

Air Tube Disc Clutches and Brakes

High Torque Clutches Specifications

Model Size ATD-	Assembly Number	Slip Torque Capacity				Duty Factors HP/100 RPM				Max. Bore Rect. Key	
		lb.in.		Nm		A	B	C	D	in.	(mm)
		80 PSI	100 PSI	5.5 BAR	7 BAR						
HTC 104	6-004-100-400-0	800	1,000	90	113	1.6	1.2	0.6	0.3	1.00	(25)
HTC 204	6-004-200-802-0	1,600	2,000	180	226	3.2	2.4	1.2	0.6		
HTC 106	6-006-100-400-0	4,000	5,000	475	602	8	5.7	2.8	1.4	2.00	(50)
HTC 206	6-006-200-400-0	8,000	10,000	950	1,204	16	11.4	5.7	2.8		
HTC 108	6-008-100-407-0	8,800	11,000	977	1,243	17	13	6	3		
HTC 208	6-008-200-417-0	17,600	22,000	1,953	2,486	34	25	13	6	2.38	(60)
HTC 308	6-008-300-400-0	26,400	33,000	2,930	3,729	51	38	19	9		
HTC 111	6-011-100-408-0	20,000	25,000	2,220	2,825	38	28	14	7		
HTC 211	6-011-200-422-0	40,000	50,000	4,440	5,650	76	56	28	14	2.63	(67)
HTC 311	6-011-300-406-0	60,000	75,000	6,660	8,475	114	84	42	21		
HTC 114	6-014-100-405-0	38,400	48,000	4,261	5,423	75	55	27	14	4.13	(105)
HTC 214	6-014-200-403-0	76,800	96,000	8,522	10,846	160	114	55	28	3.63	(92)
HTC 314	6-014-300-411-0	115,200	144,000	12,783	16,269	225	165	81	42	4.63	(118)
HTC 116	6-016-100-403-0	59,480	74,350	6,600	8,400	118	91	47	24		
HTC 216	6-016-200-402-0	118,960	148,700	13,200	16,800	236	182	94	47	4.00	(102)
HTC 316	6-016-300-401-0	178,440	223,050	19,800	25,200	354	272	142	71		
HTC 118	6-018-100-400-0	84,000	105,000	9,321	11,863	165	120	60	30		
HTC 218	6-018-200-400-0	168,000	210,000	18,642	23,726	330	240	120	60	4.75	(120)
HTC 318	6-018-300-400-0	252,000	315,000	27,963	35,589	495	360	180	90		
HTC 121	6-021-100-400-0	136,000	170,000	15,091	19,207	270	208	108	54		
HTC 221	6-021-200-401-0	272,000	340,000	30,182	38,414	540	415	216	108	6.00	(152)
HTC 321	6-021-300-400-0	408,000	510,000	45,273	57,621	810	623	324	162		
HTC 124	6-024-100-401-0	192,000	240,000	21,305	27,116	385	280	140	70		
HTC 224	6-024-200-405-0	384,000	480,000	42,610	54,232	770	560	280	140	6.00	(152)
HTC 324	6-024-300-401-0	576,000	720,000	63,915	81,348	1,155	840	420	210		
HTC 424	6-024-400-400-0	768,000	960,000	85,220	108,464	1,540	1,120	560	280		
HTC 127	6-027-100-404-0	289,680	362,100	32,144	40,911	575	442	230	115	6.50	(165)
HTC 227	6-027-200-411-0	579,360	724,200	64,288	81,821	1,150	884	460	230		
HTC 327	6-027-300-402-0	869,040	1,086,300	96,432	122,732	1,724	1,326	690	345	6.00	(152)
HTC 130	6-030-100-400-0	376,000	470,000	41,722	53,101	750	535	270	135	7.25	(184)
HTC 230	6-030-200-408-0	752,000	940,000	83,445	106,203	1,500	1,070	540	270		
HTC 330	6-030-300-415-0	1,128,000	1,410,000	125,167	159,304	2,250	1,605	810	405	8.00	(203)
HTC 136	6-036-100-400-0	752,000	940,000	84,445	106,200	1,555	1,120	560	280	8.00	(203)
HTC 236	6-036-200-409-0	1,504,000	1,880,000	166,890	212,400	3,100	2,240	1,120	560		
HTC 336	6-036-300-404-0	2,256,000	2,820,000	250,335	318,600	4,665	3,360	1,680	840	9.25	(235)
HTC 148	6-048-100-400-0	1,888,000	2,360,000	209,500	266,637	3,745	2,690	1,345	670		
HTC 248	6-048-200-406-0	3,776,000	4,720,000	419,000	533,273	7,490	5,380	2,690	1,345	18.00	(455)
HTC 348	6-048-300-403-0	5,664,000	7,080,000	628,500	799,910	11,235	8,070	4,035	2,010		

Maximum Air Pressure is 100 PSI / 7 BAR.

Air Tube Disc Clutches and Brakes

High Torque Clutches Specifications

Model Size ATD-	Recom- mended Clearance in.	Balance Speed RPM	Max. Speed		Swept Area in. ²	Airtube Volume in. ³ (cm ³)		Total Clutch				Hub & Center Plate			
			Reg- Speed RPM	High Speed RPM*		New	Worn	Wt.		WR ² / J=mr ²		Wt.		WR ² / J=mr ²	
								lb.	(kg)	lb.ft. ²	(kgm ²)	lb.	(kg)	lb.ft. ²	(kgm ²)
HTC 104	1/32-1/16	NA	2,100	2,600*	17	1.3	5	11.0	(5)	0.4	(0.018)	1.50	(0.7)	0.021	(0.001)
HTC 204	1/32-1/16	NA	2,100	2,600*	34	(21.3)	(82)	14.0	(6)	0.6	(0.023)	3.88	(1.8)	0.04	(0.002)
HTC 106	1/16-3/32	NA	2,100	2,600*	39	3	14	22.5	(10)	1.4	(0.059)	6.40	(2.9)	0.24	(0.010)
HTC 206	3/32-5/32	NA	2,100	2,600*	78	(49)	(229)	44.2	(20)	3.1	(0.131)	12.60	(5.7)	0.50	(0.021)
HTC 108	1/16-1/8				56	5	30	109.4	(50)	21.43	(0.903)	15	(6.8)	1.35	(0.057)
HTC 208	3/32-5/32	1,675	1,890	2,500*	112	(82)	(492)	148.4	(67)	28.72	(1.211)	30	(13.6)	2.60	(0.110)
HTC 308	1/8-3/16				168			140	(64)	30	(1.265)	40.5	(18.4)	4.00	(0.169)
HTC 111	1/16-1/8				114	8	48	133	(60)	27	(1.14)	23	(10.4)	2.30	(0.097)
HTC 211	3/32-5/32	1,200	1,430	2,200*	228	(131)	(787)	170	(77)	34	(1.43)	45	(20.4)	4.50	(0.190)
HTC 311	1/8-3/16				342			208	(94)	52	(2.19)	121	(54.9)	7.00	(0.295)
HTC 114	1/16-1/8				158	12	75	120	(54)	31	(1.31)	48	(21.8)	5.6	(0.236)
HTC 214	3/32-5/32	950	1,225	1,930*	316	(197)	(1,229)	265	(120)	70	(2.95)	78	(35.4)	11.2	(0.472)
HTC 314	1/8-3/16				474			279	(127)	72	(3.04)	31	(14.1)	15.1	(0.637)
HTC 116	1/16-1/8				228	10	56	236	(107)	84	(3.54)	50	(22.7)	8.2	(0.346)
HTC 216	3/32-5/32	835	1,080	1,700*	455	(164)	(918)	295	(134)	105	(4.43)	107	(48.5)	19.6	(0.826)
HTC 316	1/8-3/16				683			357	(162)	120	(5.06)	151	(68.5)	28.6	(1.206)
HTC 118	1/16-1/8				264	18	101	375	(170)	182	(7.67)	80	(36.3)	15.6	(0.658)
HTC 218	3/32-5/32	750	985	1,530*	528	(295)	(1,655)	485	(220)	200	(8.43)	118	(53.5)	28.8	(1.214)
HTC 318	1/8-3/16				792			530	(240)	250	(10.54)	180	(81.6)	45.0	(1.897)
HTC 121	3/32-5/32				362	38	201	557	(253)	334	(14.08)	101	(45.8)	31	(1.31)
HTC 221	1/8-3/16	650	850	1,400*	724	(623)	(3,294)	697	(316)	427	(18.00)	198	(89.8)	61	(2.57)
HTC 321	5/32-7/32				1,086			757	(343)	400	(16.86)	290	(131.5)	122	(5.14)
HTC 124	3/32-5/32				574			702	(318)	498	(20.99)	134	(60.8)	56	(2.4)
HTC 224	1/8-3/16	550	765	1,210*	1,148	50	250	920	(417)	635	(26.77)	260	(117.9)	110	(4.6)
HTC 324	5/32-7/32				1,722	(819)	(4,097)	1,190	(540)	856	(36.09)	386	(175.1)	163	(6.9)
HTC 424	3/16-1/4				2,296			1,291	(586)	917	(38.66)	466	(211.4)	209	(8.8)
HTC 127	3/32-5/32				730	61	323	989	(449)	785	(33.1)	168	(76.2)	98	(4.1)
HTC 227	1/8-3/16	500	700	1,090*	1,460	(1,000)	(5,293)	1,192	(541)	968	(40.8)	304	(137.9)	191	(8.1)
HTC 327	5/32-7/32				2,190			1,413	(641)	1,183	(49.9)	455	(206.4)	283	(11.9)
HTC 130	3/32-5/32				827	80	395	1,525	(692)	1,836	(77.4)	272	(123.4)	186	(7.8)
HTC 230	1/8-3/16	450	620	1,000*	1,654	(1,311)	(6,473)	1,925	(873)	2,425	(102.2)	529	(240.0)	369	(15.6)
HTC 330	5/32-7/32				2,481			2,240	(1,016)	2,720	(114.7)	800	(362.9)	495	(20.9)
HTC 136	3/32-5/32				1,150			2,190	(993)	3,650	(153.9)	376	(170.6)	368	(15.5)
HTC 236	1/8 -3/16	375	525	800*	2,300	120	770	2,800	(1,270)	4,390	(185.1)	750	(340.2)	755	(31.8)
HTC 336	5/32-7/32				3,450	(1966)	(12618)	3,221	(1,461)	4,866	(205.1)	1,206	(547.0)	1,140	(48.1)
HTC 148	1/8-1/4				2,010	200	1,430	7,326	(3,323)	25,703	(1,084)	1,711	(776)	1,828	(77)
HTC 248	7/32-9/32	275	380	580*	4,020	(3,277)	(23,434)	8,497	(3,854)	28,356	(1,195)	1,994	(904)	3,411	(144)
HTC 348	3/16-5/16				6,030			9,768	(4,431)	32,008	(1,349)	2,708	(1,228)	4,899	(207)

* Consult Factory for Special Assembly Number.

B

Air Tube Disc Clutches and Brakes

High Torque Clutches

Component Parts

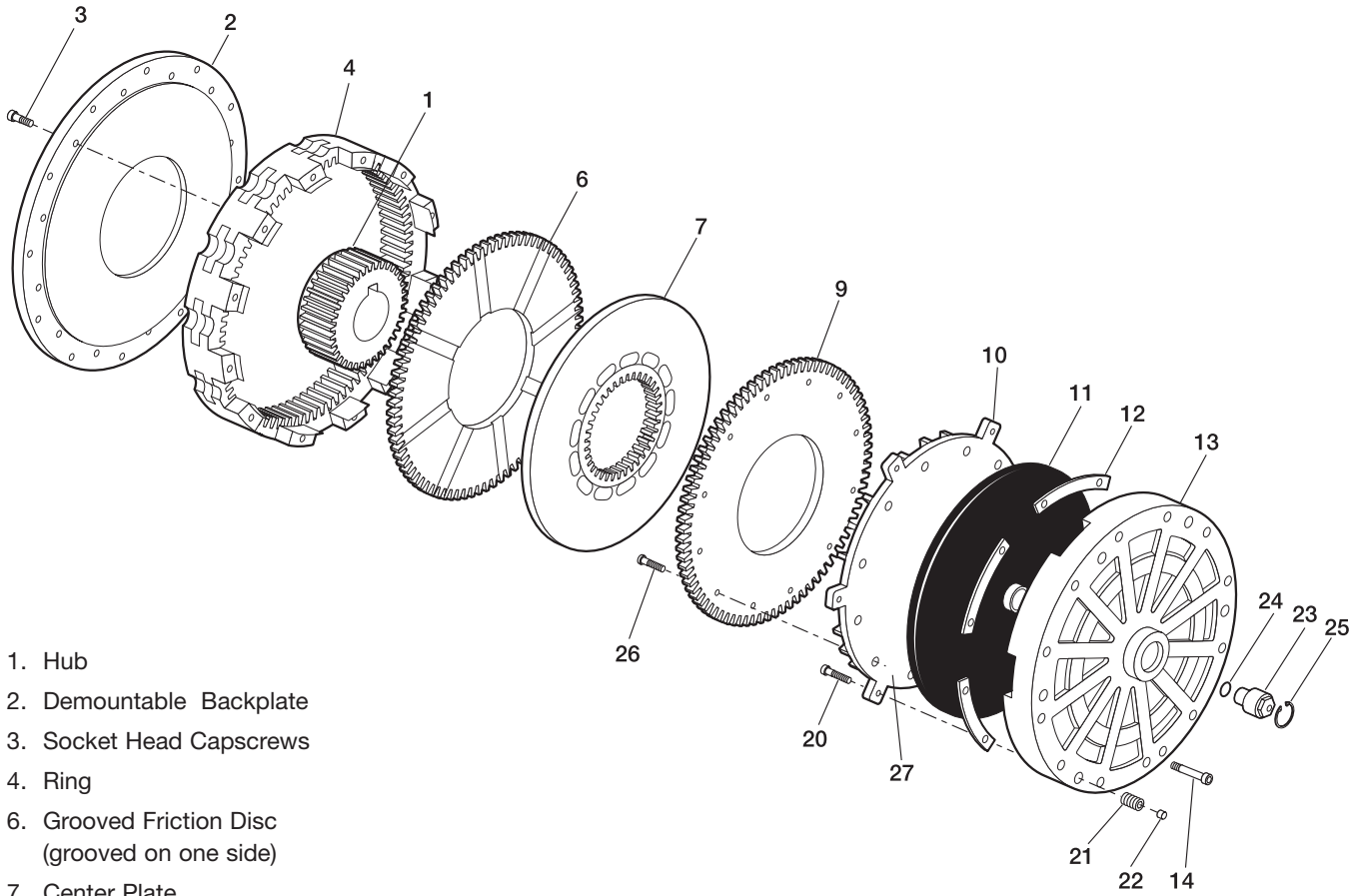

- 1. Hub
- 2. Demountable Backplate
- 3. Socket Head Capscrews
- 4. Ring
- 6. Grooved Friction Disc (grooved on one side)
- 7. Center Plate
- 9. Grooved Friction Disc
- 10. Pressure Plate
- 11. Pancake Air Tube
- 12. Shims
- 13. Air Tube Holding Plate
- 14. Socket Head Capscrews
- 20. Hex Head Capscrew
- 21. Release Springs
- 22. Flexloc Nut
- 23. Internal Roto-Coupling
- 24. "O" Ring
- 25. Snap Ring
- 26. Flathead Socket Capscrew
- 27. Slotted Flush Nut



Air Tube Disc Clutches and Brakes

High Torque Clutches

Inflation Coefficients

Model Size ATD-	Inflation Coefficients Operating Air Pressure					
	50 PSI		75 PSI		100 PSI	
	K	U	K	U	K	U
111	393,000	3	151,000	3	5,100	4
211	393,000	3	151,000	3	5,100	4
114	49,000	3	30,000	3	17,600	3
214	49,000	3	30,000	3	17,600	3
118	5,700	2.8	5,700	2.8	7,500	3
218	5,700	2.8	5,700	2.8	7,500	3
124	10,400	3	5,200	2.7	2,600	2.5
224	10,400	3	5,200	2.7	2,600	2.5
130	940	2.2	1,070	2.2	590	2
230	940	2.2	1,070	2.2	590	2
136	77,000	3.5	58,000	3.5	44,000	3.5
236	77,000	3.5	58,000	3.5	44,000	3.5
148	1,200	2.5	1,240	3.5	800	2.5
248	1,200	2.5	1,240	3.5	800	2.5

Exhaust Coefficients

Model Size ATD-	Exhaust Coefficients Operating Air Pressure								
	50 PSI			75 PSI			100 PSI		
	R	E	V	R	E	V	R	E	V
111	480,000	.04	4	180,000	.05	4	*	.056	5
211	480,000	.04	4	180,000	.05	4	*	.056	5
114	5,600	.032	2.5	2,200	.044	2.5	910	.064	2.5
214	5,600	.032	2.5	2,200	.044	2.5	910	.064	2.5
118	4,100	.062	3	9,800	.1	4	8,500	.104	4
218	4,100	.062	3	9,800	.1	4	8,500	.104	4
124	280	.06	2	775	.068	2.5	575	.078	2.5
224	280	.06	2	775	.068	2.5	575	.078	2.5
130	690	.072	2.5	500	.083	2.5	500	.084	2.5
230	690	.072	2.5	500	.083	2.5	500	.084	2.5
136	86	.048	1.5	76	.056	1.5	1,100	.064	1.5
236	86	.048	1.5	76	.056	1.5	1,100	.064	1.5
148	160	.11	2.3	120	.136	2.4	111	.15	2.5
248	160	.11	2.3	120	.136	2.4	111	.15	2.5

* 1.88 x 10⁶

Air Tube Disc Clutches and Brakes

Air System Data

PSI pressure

Inflation

Clutch air pressure during inflation can be closely estimated by the following:

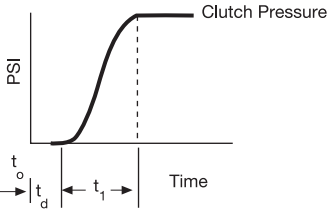

$$t_1 = \left(\frac{3}{K}\right)^{\frac{1}{U}} \text{ sec.} = \text{Time to 95\% Full Inflation}$$

$$\text{Clutch pressure} = P_1 \left(1 - \frac{1}{e^{Kt^U}}\right) \text{ PSI (inflation)}$$

This equation is accurate from 5% up to 95% P_1 .

P_1 = Line pressure to clutch PSI

K and U = coefficients for specific clutch and air pressure from Specification Table on page 51.

e = Napierian base log

t_o = Time at initiation of signal for inflation sec.

t_d = Time delay of air system – sec.

Exhaust

Clutch air pressure during exhaust can be closely estimated by the following:

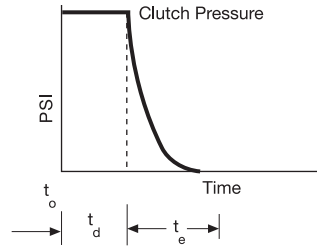

$$\text{Clutch pressure} = (P_1) (R) (E-t)^V \text{ PSI (exhaust)}$$

R , E and V = coefficients for specific clutch and air pressure from Specification Table on page 51.

t_e = Time to exhaust = E from Specification Table on page 51.

t = Time variable – seconds. In the exhaust equation “ t ” cannot exceed the value of “ E ” sec.

Shown are some of the air systems used on Wichita clutches. These systems are acceptable for remote operation where clutch reaction time is not important. Faster clutch reaction time is accomplished as indicated in the diagram by locating the flow control valve, if required, and the solenoid valve as close as possible to the roto-coupling. Where clutches are located on long shafts, the use of quick release valves on the clutch will facilitate faster clutch response.

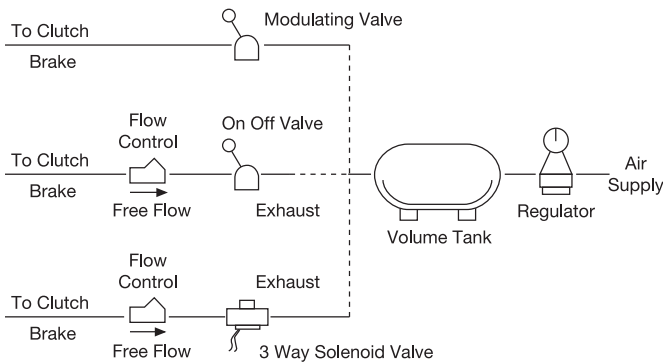

Air Tube Disc Clutches and Brakes

Air System Data

PSI pressure

Overlap

A typical clutch-brake torque curve for a single backshaft press (cyclic application) would appear as shown below.

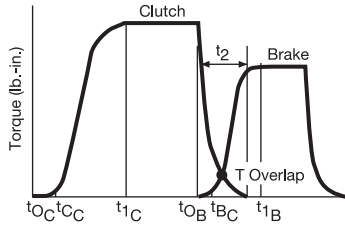

Time (sec.)

- t_{Oc} = time at which disengaged clutch receives signal
- t_{Cc} = time of clutch engagement
- t_{1c} = time of clutch full inflation
- t_{Ob} = time at which disengaged brake receives signal
- t_{Bc} = time of brake engagement
- t_{1B} = time of brake full exhaust
- t_2 = overlap time at which clutch and brake are both engaged

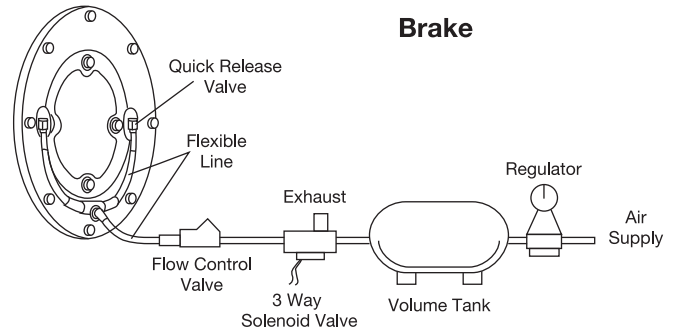
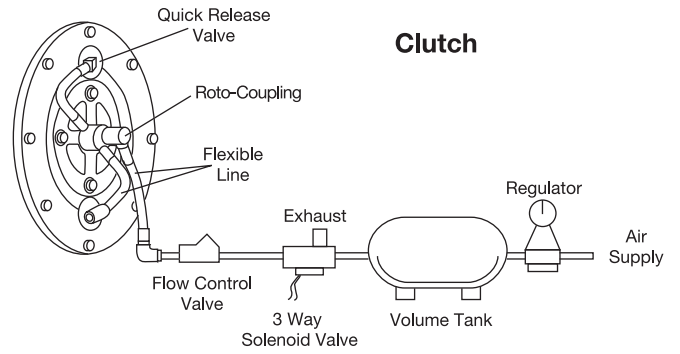

Air Tube Disc Clutches and Brakes

High Torque Clutches

Sizes 4-24

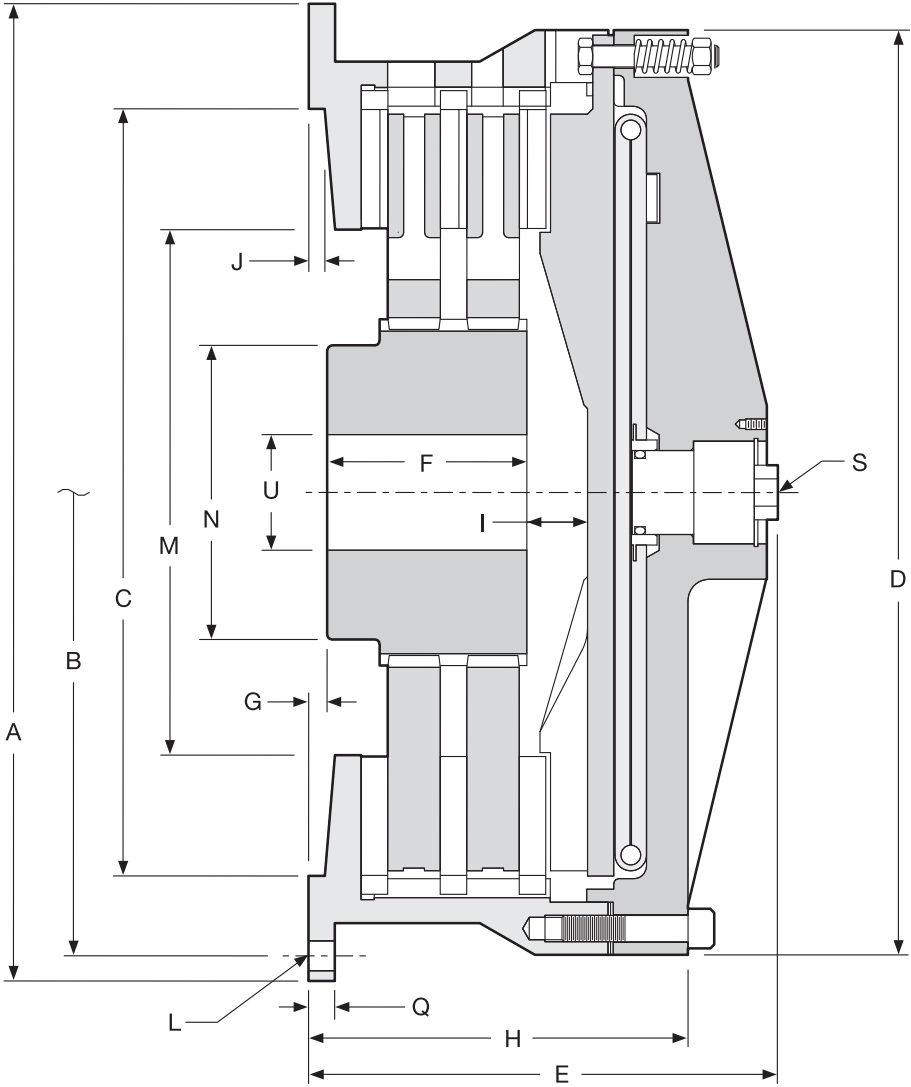

Air Tube Disc Clutches and Brakes

High Torque Clutches

Sizes 4-24

Dimensions: inches (mm)

Model Size ATD-	A	B Hole Circle	C Pilot	D	E	F	G	H
HTC 104 ²	7.38	6.875	4.375 / 4.378	6.38	3.38 (85.9)	1.00 (25.4)	0.06 (1.5)	2.50 (63.5)
HTC 204 ²	(187.5)	(174.63)	(111.13 / 111.20)	(162.1)	2.50 (63.5)	1.88 (47.8)	0.00 (0.0)	3.19 (81.0)
HTC 106 ³	8.75	8.000	7.377 / 7.379	8.81	5.03 (127.8)	2.00 (50.8)	0.00 (0.0)	4.53 (115.1)
HTC 206	(222.3)	(203.20)	(187.38 / 187.43)	(223.8)	6.25 (158.8)	3.25 (82.6)	0.06 (1.5)	5.75 (146.1)
HTC 108 ¹	12.13	11.125	8.375 / 8.378	11.13	6.21 (157.7)	1.50 (38.1)	0.50 (12.7)	4.37 (111.0)
HTC 208 ¹	(308.1)	(282.58)	(212.73 / 212.80)	(282.7)	7.52 (191.0)	2.88 (73.2)		5.68 (144.3)
HTC 111 ¹	16.00	14.750	11.375 / 11.378	14.75	7.82 (198.6)	2.00 (950.8)	0.50 (12.7)	5.44 (138.2)
HTC 211 ¹	(406.4)	(374.65)	(288.93 / 289.00)	(374.7)	9.63 (244.6)	3.75 (95.3)		7.25 (184.2)
HTC 114 ¹					8.39 (213.1)	3.75 (95.3)	.13 (3.3)	6.06 (153.9)
HTC 214	18.75	17.500	14.375 / 14.378	17.50	10.50 (266.7)	4.50 (114.3)	.38 (9.7)	7.88 (200.2)
HTC 314 ³	(476.3)	(444.50)	(365.13 / 365.20)	(444.5)	10.00 (254.0)	4.50 (114.3)	.38 (9.7)	7.88 (200.2)
HTC 116					9.16 (232.7)	2.75 (69.9)		6.78 (172.2)
HTC 216	21.25	20.000	16.250 / 16.253	20.00	11.16 (283.5)	4.75 (120.7)	0.38 (9.7)	8.66 (220.0)
HTC 316	(539.8)	(508.00)	(412.75 / 412.83)	(508.0)	13.06 (331.7)	6.63 (168.4)		10.69 (271.5)
HTC 118					9.28 (235.7)	2.75 (69.9)		7.16 (181.9)
HTC 218	23.25	22.000	18.250 / 18.253	22.00	11.20 (283.5)	4.75 (120.7)	0.44 (11.2)	9.03 (229.4)
HTC 318	(590.6)	(558.80)	(463.55 / 463.63)	(558.8)	12.81 (325.4)	6.50 (165.1)		10.94 (277.9)
HTC 121					10.19 (258.8)	2.88 (73.2)	0.69 (17.5)	7.56 (192.0)
HTC 221	27.00	25.500	21.375 / 21.378	24.88	11.83 (300.5)	5.13 (130.3)	0.75 (19.1)	9.69 (246.1)
HTC 321	(685.8)	(647.70)	(542.93 / 543.00)	(632.0)	14.19 (360.4)	7.13 (181.1)	0.75 (19.1)	12.06 (306.3)
HTC 124					10.06 (255.5)	3.50 (88.9)	0.38 (9.7)	8.38 (212.9)
HTC 224	30.00	28.750	24.375 / 24.378	28.00	12.38 (314.5)	3.50 (88.9)	0.75 (19.1)	10.69 (271.5)
HTC 324	(762.0)	(730.25)	(619.13 / 619.20)	(711.2)	14.69 (373.1)	5.13 (130.3)	0.75 (19.1)	13.00 (330.2)
HTC 424 ³	29.00	26.75	25.500 / 25.503	28.00	15.64 (397.3)	8.38 (212.9)	0.72 (18.3)	13.81 (350.8)
	(736.6)	(679.5)	(647.70 / 647.78)	(711.2)				

Dimensions: inches (mm)

Model Size ATD-	I	J	L		M	N	Q	S	U	
			No. -	Size					Min.	Max.
HTC 104	.38 (9.7)								0.50	1.00
HTC 204	.63 (16)	0.13 (3.3)	6 -	9/32 (7.1)	2.88 (73.2)	2.58 (65.5)	0.38 (9.7)	5/8-18NF	(12.7)	(25)
HTC 106	.94 (23.9)								1.00	2.00
HTC 206	.82 (20.8)	0.06 (1.5)	4 -	11/32 (8.7)	4.19 (106.4)	2.69 (68.3)	0.56 (14.2)	5/8-18NF	(25)	(50.8)
HTC 108	.81 (20.6)								1.00	2.38
HTC 208	.75 (19.1)	0.25 (6.4)	6 -	17/32(13.5)	5.38 (136.7)	3.62 (91.9)	0.50 (12.7)	1/4 NPT	(25)	(60.5)
HTC 111	1.06 (26.9)								1.00	2.63
HTC 211	1.12 (28.4)	0.38 (9.7)	6 -	11/16 (17.5)	7.00 (177.8)	4.12 (104.6)	1.13 (28.7)	1/2 NPT	(25)	(66.8)
HTC 114	1.06 (26.9)	.38 (9.7)		11/16 (17.5)	9.44 (239.8)	5.62 (142.7)	1.13 (28.7)			4.13 (104.9)
HTC 214	.81 (20.6)	.38 (9.7)	8 -	21/32 (16.7)	9.44 (239.8)	5.50 (139.7)	0.63 (16.0)	1/2 NPT	1.38 (35.1)	3.63 (92.2)
HTC 314	.94 (23.9)	.13 (3.3)		5/8-11NC	9.50 (241.3)	6.66 (169.2)	—			4.63 (117.6)
HTC 116	1.25 (31.8)			11/16 (17.5)					1.38	4.00
HTC 216	1.25 (31.8)	0.38 (9.7)	12 -	21/32 (16.7)	10.50 (266.7)	6.00 (152.4)	0.63 (16.0)	1/2 NPT	(35.1)	(101.6)
HTC 316	1.13 (28.7)			21/32 (16.7)						
HTC 118				21/32 (16.7)						
HTC 218	1.44 (36.6)	0.38 (9.7)	12 -	11/16 (17.5)	12.50 (317.5)	7.00 (177.8)	0.63 (16.0)	1/2 NPT	2.00 (50.8)	4.75 (120.7)
HTC 318				21/32 (16.7)						
HTC 121	1.50 (38.1)									
HTC 221	1.31 (33.3)	0.31 (7.9)	12 -	21/32 (16.7)	14.50 (368.3)	9.00 (228.6)	0.75 (19.1)	1/2 NPT	2.00 (50.8)	6.00 (152.4)
HTC 321	1.44 (36.6)									
HTC 124	1.13 (28.7)									
HTC 224	1.38 (35.1)	0.25 (6.4)	12 -	21/32(16.7)	14.50 (368.3)	9.00 (228.6)	0.75 (19.1)	1/2 NPT	2.00 (50.8)	6.00 (152.4)
HTC 324	1.56 (39.6)									
HTC 424 ³	1.56 (39.6)	0.13 (3.3)	12 -	5/8-11NC	14.50 (368.3)	9.00 (228.6)	—	1/2 NPT	2.00 (50.8)	6.00 (152.4)

Note: For mounting, use socket head capscrews conforming to the ASTM-574-97a.

¹ Non-Ventilated center plate, "centerplate is solid".

² Drive plate assembly, "friction material is attached to a drive plate".

³ Less backplate.

(Consult factory for drawing before final layout.)

Air Tube Disc Clutches and Brakes

High Torque Clutches

Sizes 27-48

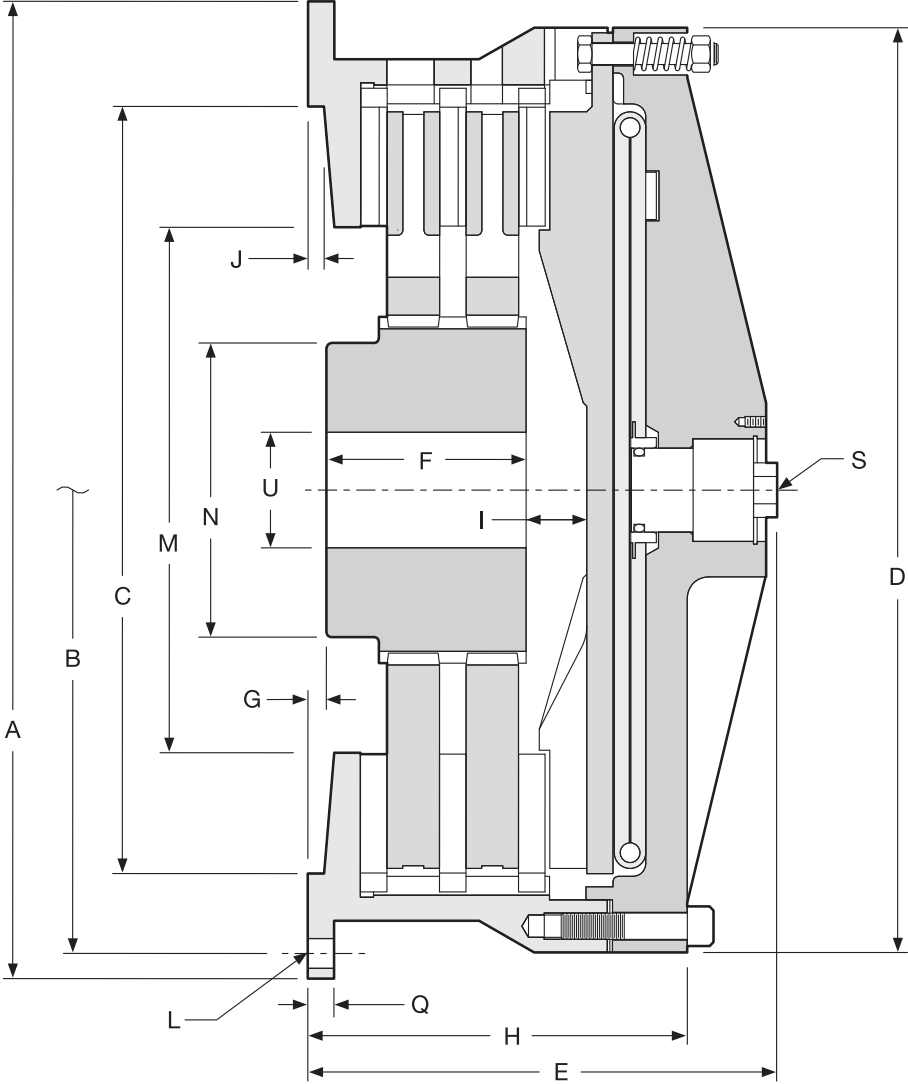

Air Tube Disc Clutches and Brakes

High Torque Clutches

Sizes 27-48

Dimensions: inches (mm)

Model Size ATD-	A	B Hole Circle	C Pilot	D	E	F	G	H
HTC 127	32.75	31.500	27.375 / 27.378	31.00	10.34 (262.6)	3.50 (88.9)		8.50 (215.9)
HTC 227	(831.9)	(800.10)	(695.33 / 695.40)	(787.4)	12.75 (323.9)	5.50 (139.7)	0.75 (19.1)	10.91 (277.1)
HTC 327					15.39 (390.9)	7.94 (201.7)		13.34 (338.8)
HTC 130	37.00	35.500	30.375 / 30.378	36.13	11.44 (290.6)	4.25 (108.0)		10.06 (255.5)
HTC 230	(939.8)	(901.70)	(771.53 / 771.60)	(917.7)	14.75 (374.7)	7.50 (190.5)	0.75 (19.1)	13.38 (339.9)
HTC 330					16.25 (412.8)	9.50 (241.3)		15.13 (384.3)
HTC 136	43.50	42.000	36.375 / 36.378	41.50	11.88 (301.8)	4.13 (104.9)	1.13 (28.7)	11.63 (295.4)
HTC 236	(1,104.9)	(1,066.80)	(923.93 / 924.00)	(1,054.1)	15.31 (388.9)	7.50 (190.5)	1.13 (28.7)	15.06 (382.5)
HTC 336					18.75 (476.3)	10.75 (273.1)	1.25 (31.8)	18.50 (469.9)
HTC 148	61.00	58.000		59.00	26.44(671.6)	6.00 (152.4)	1.00 (25.4)	17.13 (435.1)
	(1,525.0)	(1,473.2)		(1,498.6)				
HTC 248	62.00	60.000	52.000 / 52.005	57.00	30.12 (765.0)	8.75(222.3)	1.75 (44.5)	20.81(528.6)
	(1,574.8)	(1,524.0)	(1,320.8 / 1,320.9)	(1,447.8)				
HTC 348 ¹	61.00	58.000		59.00	23.44 (595.4)	12.63 (320.8)	0.00 (0.0)	23.44 (595.4)
	(1,525.0)	(1,473.2)		(1,498.6)				

Dimensions: inches (mm)

Model Size ATD-	I	J	L		M	N	Q	S	U	
			No. -	Size					Min.	Max.
HTC 127	1.50 (38.1)					10.50 (266.7)		1/2 NPT		6.50 (165.1)
HTC 227	1.63 (41.4)	0.25 (6.4)	16 -	21/32 (16.7)	16.25 (412.8)	10.50 (266.7)	.75 (19.1)	1 NPT	2.50 (63.5)	6.50 (165.1)
HTC 327	1.63 (41.4)					9.00 (228.6)		1-1/2 -12NF		6.00 (152.4)
HTC 130	1.38 (35.1)					11.00 (279.4)		1/2 NPT		7.25 (184.2)
HTC 230	1.38 (35.1)	0.25 (6.4)	18 -	25/32 (19.8)	19.25 (489)	11.00 (279.4)	.75 (19.1)	1/2 NPT	2.50 (63.5)	7.25 (184.2)
HTC 330	1.00 (25.4)					12.00 (304.8)		1-1/2 -12NF		8.00 (203.2)
HTC 136						12.00 (304.8)				8.00 (203.2)
HTC 236	1.50 (38.1)	0.25 (6.4)	18-	1-1/32 (26.2)	23.63 (600.2)	12.00 (304.8)	1.50 (38.1)	1/2 NPT	6.00 (152.4)	8.00 (203.2)
HTC 336						14.00 (355.6)				9.25 (235.0)
HTC 148	2.70 (68.6)	0.25 (6.4)	24 -	1-1/16 (27.0)	32.00 (812.8)	25.75 (654.1)	1.75 (44.5)	2 NPT	6.00 (152.4)	18.00 (457.2)
HTC 248	3.44 (87.4)						1.50 (38.1)			
HTC 348 ¹	3.96 (100.6)	0.23 (5.8)	24 -	1-9/32 (32.5)	31.88 (809.8)	24.00 (609.6)	1.50 (38.1)	2-1/2 NPT	6.00 (152.4)	18.00 (457.2)

NOTE: For mounting, use socket head capscrews conforming to the ASTM-574-97a.

¹ Less backplate.

(Consult factory for drawing before final layout.)