

Industrial Brakes

# Stromag CSH

Hydraulic Power Pack

**NEW**

**Hydraulic Power Packs type CSH are designed to be associated with calipers SH or monospring calipers SHD.**

The hydraulic Power Packs type CSH comply with requirements of inshore and offshore tower cranes and boom cranes. They allow adjustable and progressive application of the braking force with non-application of the full braking force at beginning of the braking.

## Applications

- Tower Cranes - Boom Cranes
- Port Applications
- Mass Transport
- Mining and Steel

## Benefits

- Tank volume = 6 L - Max. pressure = 150 to 180 bars.
- Electrical indicators of oil temperature and level.
- C4M L anti-corrosive protection level - IP55 tightness level.
- Service life = 200,000 operations.
- Different configurations according to the customer requirement:
  - Application of the full braking force.
  - Modulation of the braking force application.
- Option: electrical unit.

**GSH Hydraulic Power Pack**

Motor 0,75 kW at 1500 rpm  
 Maximal utilization pressure: 180 bars  
 Electrical indicators of oil temperature and level (OP7-8)  
 Vertical installation

**Operating conditions:**

- Ambient temperature: -10°C to +50°C
  - Relative humidity: ≤ 100%
  - C4M L anti-corrosive protection level (according to ISO12944 standards)
  - IP55 tightness level
- Other conditions: consult us.

**Use:**

- Service life: 200 000 operations
- Max. frequency of operation: 60 op. / hour

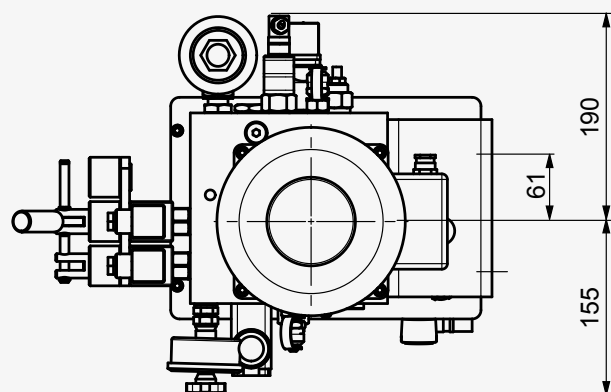
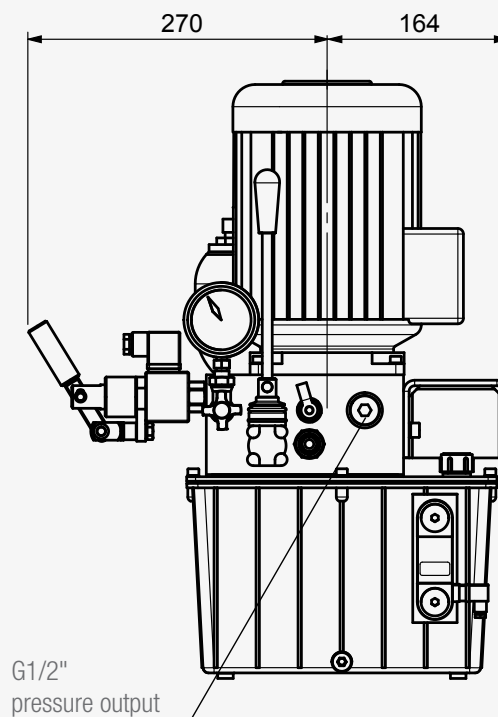
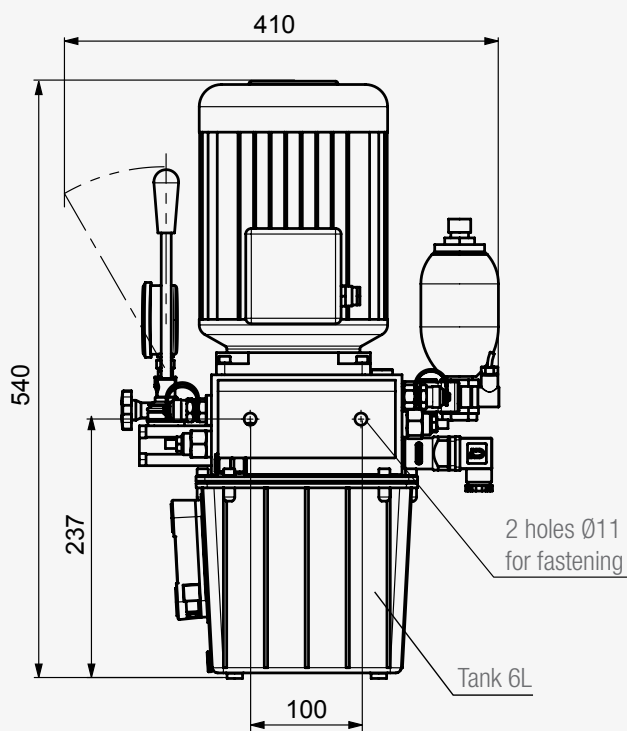

Dimensions in mm  
 Weight without oil: 36 kg  
 Tank volume: 6 L