

Electrically Release Brakes

ERD Sizes 060 to 300 & ERDD Sizes 120 to 600

Service Manual

P-2064-WE
SM321gb - rev 11/04



 **Warner**[®]
Electric

An Altra Industrial Motion Company

We, **WARNER ELECTRIC EUROPE**, 7, rue Champfleür, B.P. 20095, F-49182 St Barthélemy d'Anjou Cedex declare that the brakes herein made in our factory from St Barthélemy d'Anjou, **ERD and ERDD**

are intended to be incorporated in an installation or to be assembled with other equipment with a view to constituting a machine to which directive 89/336 as amended apply.

The basic requirements of Low Voltage directive 73/23 as amended are compiled with through full conformity with the following standards: NFC 79300 and VDE 05808/8.65

Drawn up in St Barthélemy d'Anjou, July 2002

E. PRAT, General Managing Director

CONTENTS



1	Technical specifications	2	4.3	Spare parts	4
2	Precautions and restrictions on use	2	5	Electrical connection	4
2.1	Restrictions on use	2	5.1	Important recommendations	4
2.2	Precautions and safety measures	2-3	5.2	Power supply	4
3	Installation	3	6	Options	4
3.1	Transport - storage	3	6.1	Torque adjustment	4
3.2	Handling	3	6.2	Detection kit	5
3.3	Installing	3	6.3	Hand release kit	5
4	Maintenance	3	7	Appendices	6
4.1	Adjusting the airgap	3	7.1	ERD VAR00 and VAR02	7
4.2	Maintenance	3	7.2	ERDD and options	7

1 Technical specifications VAR00, VAR02

ERD Size		060	100	170	300
Nominal torque (STANDARD version)	Nm	60	100	170	300
Nominal airgap +0,1/-0,05	mm	0,3	0,3	0,3	0,3
Pull-in airgap max.	mm	0,8	0,9	0,9	1
Nominal torque (HIGH TORQUE version)	Nm	80	130	220	400
Tightening torque of screws	mm	24	24	24	48

ERDD HT Size		120	200	340	600
Nominal torque (HIGH TORQUE version)	Nm	160	260	440	800
Nominal airgap +0,1/-0,05	mm	0,3	0,4	0,4	0,4
Pull-in airgap max.	mm	0,8	0,9	0,9	1
Tightening torque of screws	mm	24	24	24	48

Table 1

2 Precautions and restrictions on use



Symbol designating an action that might damage the brake



Symbol designating an action that might be dangerous to human safety



Symbol designating an electrical action that might be dangerous to human safety

2.1 Restrictions on use



The equipment is designed for dry running.



Exceeding the maximum rotation speeds stated in the catalogue invalidates the warranty.



The equipment can be fitted either horizontally or vertically. The ERDD and HT version can only be fitted horizontally.

This equipment is designed for an ambient temperature of 40° maximum (155°C cladding class).

2.2 Precautions and safety measures



During maintenance, ensure that the Mechanism to be braked by the equipment is at rest and that there is no risk of accidental start-up. All intervention have to be made by qualified personnel, owning this manual.



Any modification made to the brake without the express authorisation of a representative of Warner Electric, in the same way than any use out of the contractual specifications accepted by "Warner Electric", will result in the warranty being invalidated and Warner Electric will no longer be liable in any way with regard to conformity.

3 Installation

3.1 Transport / storage

These units are delivered in packaging that guarantees a 6 months storage period whether transported by land, by air, or by sea to any destination excepting tropical countries. (For tropical destinations please consult Warner Electric technical services).

3.2 Handling

 Avoid any impacts on the equipment so as not to alter their performance.

 Never carry the equipment by the electrical supply cable.

3.3 Installing

NB : ERD SZ060 to 300 brakes are supplied in kit form. The Mounted inductor is supplied airgap adjusted.

The ERDD HT brakes are delivered completely mounted, the airgap is adjusted in our workshop. See chapter 7 (appendix)

If a friction flange (341) is supplied, fix it first.

Put the key into the shaft then slide the hub (515) onto the shaft and stop it axially by suitable means.

Slide the friction disc (312) or (315) onto the hub.

Fit the mounted inductor (107) or (108), remove the wedge pieces (551) and fix it using the fixing bolts (913) or (914). These screws have to be tightened (see torque table 1). Secure the bolts using a LOCTITE 270 type thermoplastic liquid.

If a hand locking kit is supplied, it is preferable to adapt it on the mounted inductor before the inductor is fitted. (See chapter 6)

If a dust cover (555) is supplied, carefully slide it onto the equipment before fitting it.

Switch the equipment on and confirm that the friction disc rotates freely.

Make several motor manoeuvres stationary and check the value of the airgap.

If the airgap is insufficient, refer to chapter 4 (maintenance)

 Do not grease the guiding splines (friction disc / hub). It will change the brake's performances.

 **WATCH OUT !** Respect obligatory the direction of the hub when mounting (see fig. 1 below)

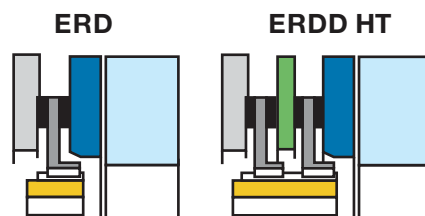

Fig. 1

4 Maintenance

4.1 Adjusting the airgap

To adjust the airgap (Fig. 2), undo the adjustment bolts in order to get the necessary value (see table 1). Check the value of the airgap at several points. Make several motor manoeuvres stationary, then again check the value of the airgap.

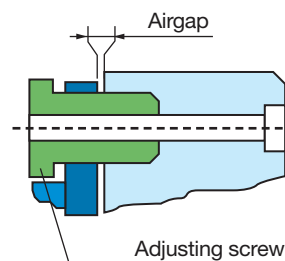

Fig. 2

ERD Size	060	100	170	300
E min (mm)	6	6	7,7	8
ERDD HT Size	120	200	340	600
E min (mm)	11,2	10	12,7	12,3

Table 2

4.2 Maintenance

Wear in the friction material causes an increase in the airgap. Before reaching the maximum airgap (see table 1), it is necessary adjust it (see above).

4.3 Spare parts



After several adjustments, variable according to size and use, it is necessary to replace the friction disc (see Fig. 3 and table 2)

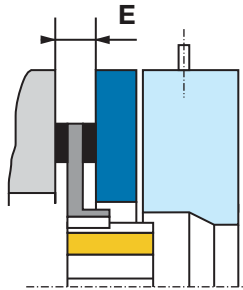

Fig. 3

To replace the friction disc(s) (312) or (315), undo the fixing bolts (913) or (914) then take off the mounted inductor (107) or (108) and then the friction disc(s). Put the new friction disc(s) into position then refit the mounted inductor and adjust the airgap (see paragraph 4.1).

5 Electrical connection

ERD and ERDD HT brakes have to be supplied with direct current and are factory fitted with 400 mm long wires. The polarity does not affect operation.

5.1 Important recommendations



All works on the electrical connections have to be made with power off.



Ensure compliance with the nominal supply voltage (inadequate supply causes a reduction in the starting distance).

The connecting wires should be of sufficient diameter to prevent voltage drops between the source and equipment supplied.

I (A) / L (m)	0 to 10 m	from 10 to 20 m
0 to 3 (A)	1,5 mm ²	1,5 mm ²
3 to 6 (A)	1,5 mm ²	2,5 mm ²

Tolerance for the supply voltage to the brake terminals +5% / -10% (NF C 79-300).

5.2 Power supply

We advise the use of Warner Electric CBC 140 1, CBC 140-2 or CBC 140-5 supply units (with overexcitation and holding voltage)

The supply and switching method has a great influence on the response time. Response times shown in our catalogues are for a supply at nominal voltage with DC side switching.

In the event of AC switching, the braking response time may be multiplied by 6.

To get very short brake release and braking times, we advise the CBC 140-5 (please ask):

- With overexcitation on brake release, the start time can be divided by 3 (according to the supply voltage)
- Adjusting the hold voltage to 50% of the nominal voltage reduces the brake engagement time and its temperature rise

Warner Electric supply units provide protection for coils and circuits. Where a brake is used without our supply units, with switching on the DC, it is essential for the coil to be protected against surges by a varistor fitted in parallel.

6 Options

6.1 Torque adjustment

Torque adjustment is only possible on VAR02 (~ 50% of nominal torque).

Brakes are supplied adjusted to nominal torque.

Principle of torque reduction:

On VAR 02 (table 3), undo the adjustment ring located at the rear of the inductor (see chapter 7).

STANDARD version

ERD Size	060	100	170	300
Nominal torque (Nm)	60	100	170	300
Max. number of turns (adjustment ring)	3	3	4,5	5,5
Theoretical reduction in torque for 1 turn of the nut (Nm)	11	16	25	34

HIGH TORQUE version

ERD Size	060	100	170	300
ERDD Size	120	200	340	600
Nominal torque (Nm)	80	130	220	400
	160	260	440	800
Max. number of turns (adjustment ring)	3	3	4,5	5,5
Theoretical reduction in torque for 1 turn of the nut (Nm)	15	21	32	45
	30	42	64	90

Table 3 (VAR02)

6.2 Detection kit

Fitting

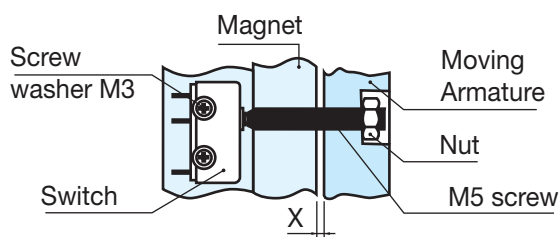

Fig. 4

Check that the brake is correctly set to the nominal airgap. Tighten the M5 bolts in the moving armature then fit the nut (see figure 4), then fix the sensor using the M5 bolts and washers.

NB : The M3 fixing bolts are self tapping.

Adjustment

Insert a shim 0,15 mm thick near the bolt between the face of the inductor and moving armature. Switch the device on, tighten the bolt to contact with the sensor until the switch point is obtained then lock the bolt using the nut.

Check correct operation by making several successive starts and releases.

Switch characteristics

Protection	IP 65
Temperature	-40°C / +120°C
Cable	3 x 0,75 mm
Switching power:	8A-250VAC / 6A - 380 VAC

Switch connection

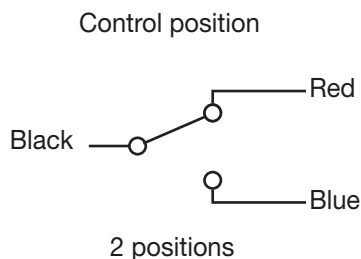

6.3 Hand release kit

Only for use with VAR02

Fitting: (Fig 5 and 6)

Check that the brake is correctly set to the nominal airgap.

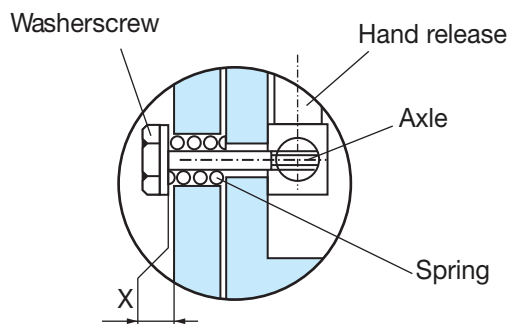

Fig. 5

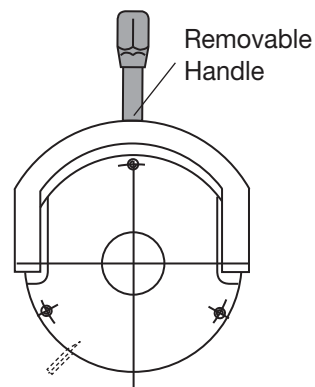

Fig. 6

Fit the spindles in the lever, the springs in the moving armature, then the bolts and washers as shown in figure 5, respecting dimension X (See table 4)

ERD size	060	100	170	300
ERDD HT size	120	200	340	600
Dim. X (+0,2/0 mm)	1	1	1	1,5

Table 4

7 Appendices

7.1 ERD VAR00, VAR02

ERD VAR00

NO.	Description
107	Mounted «AC» Magnet
108	Mounted «DC» Magnet
312	Friction disc
315	Friction disc High Torque
515	Hub
551	Wedge

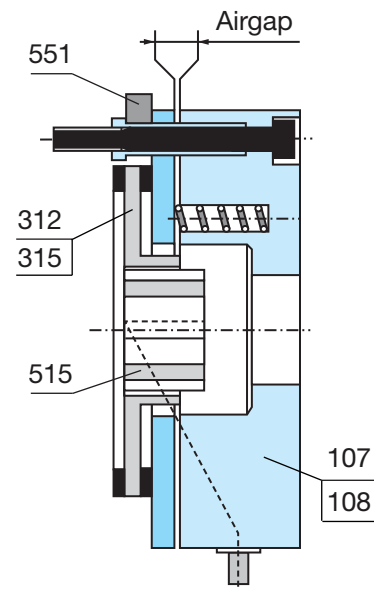

VAR00

ERD VAR02

NO.	Description
107	Mounted «AC» Magnet
108	Mounted «DC» Magnet
312	Friction disc
315	Friction disc High Torque
515	Hub
551	Wedge

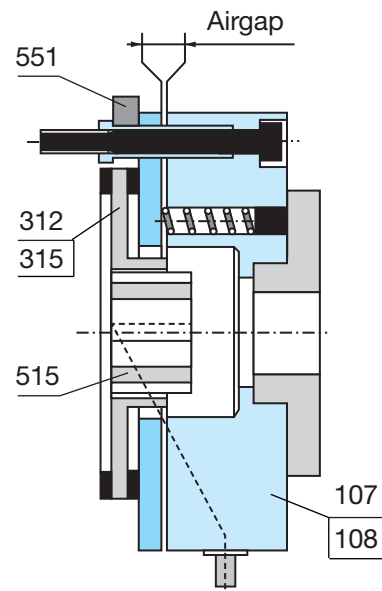

VAR02

7.2 ERDD HT and options

ERDD HT

NO.	Description
108	Mounted «DC» Magnet
312	Friction disc
315	Friction disc High Torque
320	Intermediate Disc
341	Thick Friction Flange
515	Hub
551	Wedge
914	Set of long Fixing Bolts

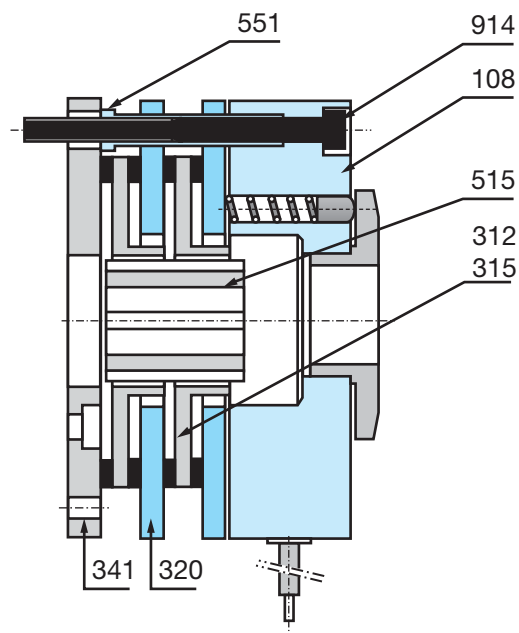

Options

NO.	Description
339	Friction flange FERMG
341	Thick friction flange
418	Hand release kit
555	Dust Cover
613	Detection Kit
617	Connector Kit
913	Set of short fixing bolts
914	Set of long fixing bolts

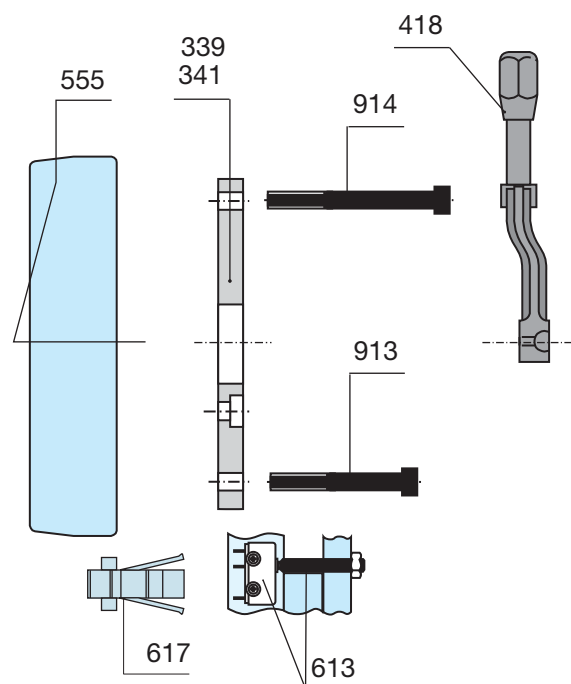

Warranty

Warner Electric LLC warrants that it will repair or replace (whichever it deems advisable) any product manufactured and sold by it which proves to be defective in material or workmanship within a period of one (1) year from the date of original purchase for consumer, commercial or industrial use.

This warranty extends only to the original purchaser and is not transferable or assignable without Warner Electric LLC's prior consent.

Warranty service can be obtained in the U.S.A. by returning any defective product, transportation charges prepaid, to the appropriate Warner Electric LLC factory. Additional warranty information may be obtained by writing the Customer Satisfaction Department, Warner Electric LLC, 449 Gardner Street, South Beloit, Illinois 61080, or by calling 815-389-3771.

A purchase receipt or other proof of original purchase will be required before warranty service is rendered. If found defective under the terms of this warranty, repair or replacement will be made, without charge, together with a refund for transportation costs. If found not to be defective, you will be notified and, with your consent, the item will be repaired or replaced and returned to you at your expense.

This warranty covers normal use and does not cover damage or defect which results from alteration, accident, neglect, or improper installation, operation, or maintenance.

Some states do not allow limitation on how long an implied warranty lasts, so the above limitation may not apply to you.

Warner Electric LLC's obligation under this warranty is limited to the repair or replacement of the defective product and in no event shall Warner Electric LLC be liable for consequential, indirect, or incidental damages of any kind incurred by reason of the manufacture, sale or use of any defective product. Warner Electric LLC neither assumes nor authorizes any other person to give any other warranty or to assume any other obligation or liability on its behalf.

WITH RESPECT TO CONSUMER USE OF THE PRODUCT, ANY IMPLIED WARRANTIES WHICH THE CONSUMER MAY HAVE ARE LIMITED IN DURATION TO ONE YEAR FROM THE DATE OF ORIGINAL CONSUMER PURCHASE. WITH RESPECT TO COMMERCIAL AND INDUSTRIAL USES OF THE PRODUCT, THE FOREGOING WARRANTY IS IN LIEU OF AND EXCLUDES ALL OTHER WARRANTIES, WHETHER EXPRESSED OR IMPLIED BY OPERATION OF LAW OR OTHERWISE, INCLUDING, BUT NOT LIMITED TO, ANY IMPLIED WARRANTIES OF MERCHANTABILITY OR FITNESS.

Some states do not allow the exclusion or limitation of incidental or consequential damages, so the above limitation or exclusion may not apply to you. This warranty gives you specific legal rights and you may also have other rights which vary from state to state.

Changes in Dimensions and Specifications

All dimensions and specifications shown in Warner Electric catalogs are subject to change without notice. Weights do not include weight of boxing for shipment. Certified prints will be furnished without charge on request to Warner Electric.



Warner Electric Europe
7 rue Champfleu, B.P. 20095, St Barthelemy d'Anjou - France
+33 (0)2 41 21 24 24 • Fax: +33 (0)2 41 21 24 70
www.warnerelectric.com