

Gen 2 Ceramic Faced Clutch/Brake UniModule

UM-50C, UM-180C

P-273-10
819-0532

Installation Instructions



 **Warner**
Electric

An Altra Industrial Motion Company

Contents

Mounting to a C-Face Motor	3
Mounting to a Reducer	4
Installing the Base Mount	4
Installing the Motor Mount Bracket	5
Mounting to Other Power	
Transmission Components	5
Electrical Connections	6
Troubleshooting-Electrical	6
Troubleshooting-Mechanical	6
Warranty	BC

⚠ WARNING Failure to follow these instructions may result in product damage, equipment damage, and serious or fatal injury to personnel.

⚠ WARNING The equipment covered by this installation manual must be installed in accordance with these instructions. Failure to do so may damage the equipment and void the warranty.

The ceramic versions of Warner Electric UniModules are completely assembled clutch/brake packages for out of box use. They are engineered for easy installation, while providing extra long life over standard units. Technically advanced ceramic friction material provides exceptional wear resistance and enhanced performance making Ceramic UniModule clutch/brakes ideal for high cycle rate applications.

Ceramic clutch/brake combinations are offered in two configurations. The "1020-C" has a hub input and a male shaft output. The "2030-C" has a male shaft extension for both input and output. These two configurations are offered with various mounting accessories to make ceramic friction faced UniModules adaptable to many power transmission systems.

The 1020-C UniModules are designed to mount to the face of a C-Face motor as noted in Table 1.

Corresponding NEMA Frame Sizes

UM Size	Old NEMA	New NEMA	Shaft Dia.	C-Face Pilot Dia.
50	56 C	48 Y	5/8"	4-1/2"
180	182 C 184 C	143 TC 145 TC	7/8"	4-1/2"

Table 1

The 2030-C UniModules are designed to mount using a base mounting kit. This allows the modules to be mounted as a separate drive unit driven from the prime mover by V-belts, chain and sprockets, couplings, timing belts and other standard power transmission components.

(For UniModule size 210-C please refer to Warner Electric manual P-273-3)

For These UM-C Combinations

Use These Installation Steps:

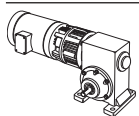

UniModule Clutch/Brake between
C-Face Motor and Reducer
1020-C

Mounting to a Motor
Mounting to a Reducer
Electrical Connections

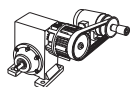

UniModule Clutch/Brake
2030-C

Mounting to other
Power Transmission
Components
Electrical Connections

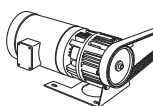

Motor Mount Module Clutch/Brake
on a C-Face Motor
1020-C-M

Mounting to a Motor
Installing the Motor
Mount Bracket
Mounting to other
Power Transmission
Components
Electrical Connections

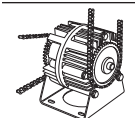

Base Mounted
UniModule Clutch/Brake
2030-C-B

Installing the Base Mount
Mounting to other
Power Transmission
Components
Electrical Connections

Install your specific Ceramic UniModule combination according to the installation steps specified in the table. Use only those steps indicated for each combination.

Mounting to a C-Face Motor

1. A hardened key is provided with the mounting hardware for Ceramic UniModules. Insert this key onto the motor shaft. It is recommended to stake the end of the motor shaft keyway to keep the key from moving out during operation.
2. Align the keyway in the bore of the UniModule to the key in the motor shaft and slide the unit onto the motor shaft. The normal alignment of the module to the motor will be with the wire exit/conduit box in the upright (12 o'clock) position as shown in Figure 1.

⚠ WARNING Do not hammer or force the module into position. To do so may damage bearings or cause the friction faces to shift out of alignment.



Figure 1

⚠ CAUTION If anti-fretting lubricant is used on the motor shaft for future ease of removal, ensure that any excess is wiped off before unit assembly to avoid lubricant contaminating the clutch or brake friction faces.

3. Secure the Ceramic UniModule to the motor with the four (4) long mounting tie-bolts provided. Tighten the four (4) bolts

alternately to ensure even alignment of the module. Tighten them to 30-35 foot pounds.

⚠ WARNING Do not tighten the two (2) clutch rotor set screws to the shaft before tightening the four (4) module tie-bolts. This could cause a preload on the pilot bearing resulting in premature bearing failure.

4. Next secure the clutch rotor and fan assembly to the motor shaft by tightening the two (2) setscrews as follows:
 - a. There are two (2) access slots on either side of the UniModule. A long Allen wrench can be used to tighten the two setscrews (90° apart) which secure the clutch rotor and fan assembly to the motor shaft.
 - b. Alternately align each setscrew with one of the access slots by rotating the clutch rotor and fan assembly through one of the side vents with a small screw driver taking care not to damage the fan. (Figure 2a)

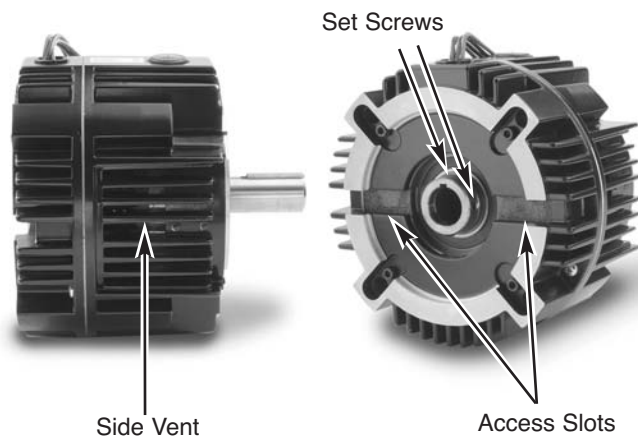

Figure 2a

- c. Using a torque wrench and long Allen socket, tighten the two (2) setscrews to: (Figure 2b)
 - Size 50: 80-85 inch pounds (Requires 5/32 inch Allen wrench)
 - Size 180: 40-45 inch pounds (Requires 1/8 inch Allen wrench)



Figure 2b

Mounting to a Reducer

1. Warner Electric UniModules are furnished with a hardened key pre-mounted on the output shaft.
2. Align the output shaft and key of the module with the corresponding bore and keyway of the reducer. Slide the assembly together as shown in Figure 3.



Figure 3

3. Bolt the module to the reducer flange. The four (4) bolts that are required (3/8-16UNC2A) are typically provided with the reducer. Tighten to 18-22 foot pounds of torque.

Installing the Base Mount

Model 2030-C UniModules are designed to be base mounted as shown in Figure 4.

Optional Base Mount Kit,
Warner Electric part numbers:

UM-50.....	5370-101-004
UM-180.....	5370-101-002



Figure 4

1. The pilot diameters on each end of the UniModule will mate with the pilot diameters on the base.
2. Secure the base to the UniModule with the four (4) bolts provided. Tighten to 18 to 22 foot pounds.

Installing the Motor Mount Bracket

A Motor Mount Bracket can be installed on the output end of a 1020-C UniModule to provide a foot mounting for the complete assembly of a UniModule and C-face motor.

Optional Motor Mount Kit,
Warner Electric part numbers:

UM-50.....5370-101-078
UM-180.....5370-101-079

1. Mount the bracket to the face of the UniModule underneath the UniModule and motor as shown in Figure 5. A pilot diameter on the UniModule mates with a pilot diameter on the bracket.



Figure 5

2. Secure the motor bracket in place with four (4) short bolts and washers provided. Tighten to 18 to 22 foot pounds.

Mounting to Other Power Transmission Components

Couplings, pulleys, sprockets or similar power transmission components can be mounted to the input and output shafts of a UniModule.

CAUTION When mounting a pulley or sprocket, ensure that the key is fully engaged within the device hub or bushing.

CAUTION Confirm that the belt or chain tightness meets the maximum side load capability of the UniModule shown in Table 2.

Overhung Load Data (Shaft Side Load)

Overhung load data is provided in this manual for the design engineer concerned with a specific problem in this area. The maximum allowable overhung load which can be applied to the shaft of a UniModule may be determined by the use of the accompanying chart.

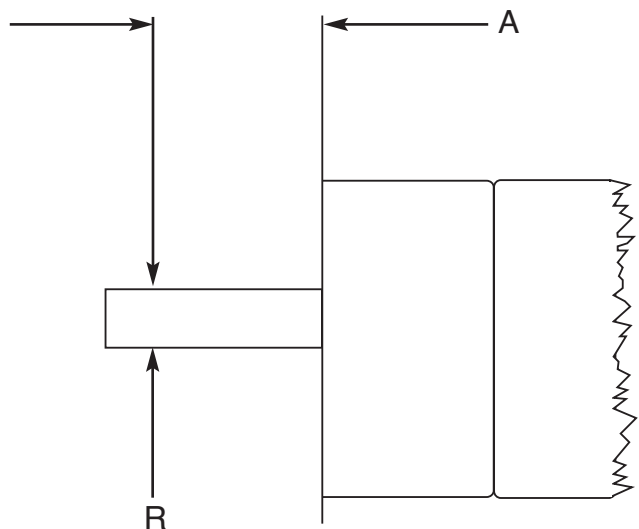

UniModule	Distance Load is Applied from Housing Face "A" Inches	Maximum Load Rating "R" Lbs.
UM-50	1" (Center of Shaft)	177
	2" (End of Shaft)	123
	3"	95
UM-180	1" (Center of Shaft)	192
	2" (End of Shaft)	134
	3"	104

Table 2

Electrical Connections

⚠ WARNING To avoid injury (or even death), always make certain all power is off before attempting to install or service this device or any electrical equipment.

Warner Electric Ceramic UniModules are provided with a conduit hole threaded for a standard 1/2 inch conduit connection. Both the clutch and brake lead wires exit this opening. If a Conduit Box is desired, Warner Electric Conduit Box Kit, part number: 5370-101-042, can be purchased separately. The Conduit Box provides two conduit connection holes for standard 1/2 inch conduit connectors.

Ceramic UniModule clutch/brakes operate on DC voltage. Warner Electric offers a complete line of electronic controls to meet the needs of almost any clutch or clutch/brake application. Each Warner Electric control will show the proper wiring connections for its use.

Troubleshooting - Electrical

If a UniModule is not functioning properly it is best to check for these problems before replacing it.

A standard Ceramic UniModule clutch/brake requires DC power to function. If power is not reaching the clutch or brake, the clutch or brake will not engage.

A good practice to follow is to check for power at the lead wires to the clutch or brake using a voltmeter.

- If power is present in the proper voltage and current (see Electrical Coil data), then skip ahead to the Mechanical Troubleshooting section.
- If power is not present, inspect the lead wires for breaks or cuts.

- If the wires are intact, the problem may be with the power supply or the switch.
- Using a voltmeter, check to see that proper DC voltage is leaving the power supply and that the switch is sending power to the clutch or brake.
- If there is no power leaving the switch or power supply, check the incoming AC power to ensure that it is reaching the power supply.
- If there is proper DC voltage present at the magnet leads, and the clutch or brake will not engage, an ohmmeter check of the individual magnet coils can be made with the power off and the circuit open. (To be certain, disconnect one lead to the magnet.) Compare resistance to the chart below.

Electrical Coil Data

		Clutch	Brake	Clutch	Brake	Clutch	Brake
Voltage-D.C.		90	90	24	24	6	6
Resistance	UM-50-C	452	452	31.8	28.8	1.86	1.86
(OHMS)	UM-180-C	392	392	26.7	26.7	1.81	1.81
Current	UM-50-C	.199	.199	.755	.833	3.23	3.23
(Amperes)	UM-180-C	.230	.230	.896	.896	3.31	3.31
Power	UM-50-C	17.9	17.9	18.1	20.0	19.4	19.4
(WATTS)	UM-180-C	20.7	20.7	21.5	21.5	20	20
Coil Build Up	UM-50-C	52	53	52	53	52	53
Time (ms)	UM-180-C	72	75	72	75	72	70
Coil Decay	UM-50-C	6.2	5.0	6.2	5.0	6.5	5.0
Time (ms)	UM-180-C	12	10	12	10	12	10

Troubleshooting - Mechanical

The Ceramic UniModule is similar to a standard UniModule except for the ceramic friction faces, and the Autogaps™ have been replaced by a compression spring between the armatures. This results in the armatures being in continuous contact with the rotor and brake resulting in light, continuous drag. This arrangement eliminates the sudden change in torque that results when autogapped armatures engage.

No adjustment is required for the life of the unit unless it is jarred, resulting in the armature being moved away from the mating surface and cocking

on the spline. If this occurs, a slight pry on the armature usually gets it back into position.

The ceramic faced friction surfaces of these UniModules are pre-burnished and performance tested at the factory to ensure consistent “out of box” performance. Therefore, no “wearing in,” or burnishing, is required. Full rated performance should be achieved after running for a few cycles, usually fewer than 50.

Mechanical Data

	UM-50-C	UM-180-C
Static Torque - lb. ft.	16	30
Maximum Speed - rpm	3600	3600
Average Weight-lbs.		
1020	15.6	18.7
2030	18.4	21.7

Inertia - WR - lb.ft.²

Configuration	50-C	180-C
1020 input	.021	.047
1020 output	.0195	.050
2030 input	.021	.048
2030 output	.0195	.050

Repair and Replacement

Ceramic UniModules will provide reliable and consistent performance throughout the exceptionally long life of the friction facings. Their long life results from the exceptional wear resistance of the ceramic material. The low wear rate also results in a longer burnish time to “mate” the friction surfaces. Alignment of the friction surfaces of both clutch and brake are also very critical. Therefore, these units are not field serviceable. All repair work must be done by the Factory where alignment and burnishing can be closely monitored.

Please note that units with damage to the non-wearing components, such as housings and shafts, are not repairable. The factory will evaluate returns and determine if they can be repaired.

⚠ WARNING The optional cover kit normally available for the standard UniModule is not recommended for use with the Ceramic UniModule. The unauthorized use of this kit with the Ceramic UniModule may void the Warranty.

Notes:

Visit Warner Electric’s website at www.warnerelectric.com for dimensional drawings, weights, inertias, and a complete offering of our products including clutches, brakes and clutch/brake controls.

In addition, Warner Electric module products, controls, and information can be found in our catalog P-1234-WE. Call 815-389-3771 to request any of our catalogs.

Warranty

Warner Electric LLC warrants that it will repair or replace (whichever it deems advisable) any product manufactured and sold by it which proves to be defective in material or workmanship within a period of one (1) year from the date of original purchase for consumer, commercial or industrial use.

This warranty extends only to the original purchaser and is not transferable or assignable without Warner Electric LLC's prior consent.

Warranty service can be obtained in the U.S.A. by returning any defective product, transportation charges prepaid, to the appropriate Warner Electric LLC factory. Additional warranty information may be obtained by writing the Customer Satisfaction Department, Warner Electric LLC, 449 Gardner Street, South Beloit, Illinois 61080, or by calling 815-389-3771.

A purchase receipt or other proof of original purchase will be required before warranty service is rendered. If found defective under the terms of this warranty, repair or replacement will be made, without charge, together with a refund for transportation costs. If found not to be defective, you will be notified and, with your consent, the item will be repaired or replaced and returned to you at your expense.

This warranty covers normal use and does not cover damage or defect which results from alteration, accident, neglect, or improper installation, operation, or maintenance.

Some states do not allow limitation on how long an implied warranty lasts, so the above limitation may not apply to you.

Warner Electric LLC's obligation under this warranty is limited to the repair or replacement of the defective product and in no event shall Warner Electric LLC be liable for consequential, indirect, or incidental damages of any kind incurred by reason of the manufacture, sale or use of any defective product. Warner Electric LLC neither assumes nor authorizes any other person to give any other warranty or to assume any other obligation or liability on its behalf.

WITH RESPECT TO CONSUMER USE OF THE PRODUCT, ANY IMPLIED WARRANTIES WHICH THE CONSUMER MAY HAVE ARE LIMITED IN DURATION TO ONE YEAR FROM THE DATE OF ORIGINAL CONSUMER PURCHASE. WITH RESPECT TO COMMERCIAL AND INDUSTRIAL USES OF THE PRODUCT, THE FOREGOING WARRANTY IS IN LIEU OF AND EXCLUDES ALL OTHER WARRANTIES, WHETHER EXPRESSED OR IMPLIED BY OPERATION OF LAW OR OTHERWISE, INCLUDING, BUT NOT LIMITED TO, ANY IMPLIED WARRANTIES OF MERCHANTABILITY OR FITNESS.

Some states do not allow the exclusion or limitation of incidental or consequential damages, so the above limitation or exclusion may not apply to you. This warranty gives you specific legal rights and you may also have other rights which vary from state to state.

Changes in Dimensions and Specifications

All dimensions and specifications shown in Warner Electric catalogs are subject to change without notice. Weights do not include weight of boxing for shipment. Certified prints will be furnished without charge on request to Warner Electric.



Warner Electric LLC
449 Gardner Street • South Beloit, IL 61080
815-389-3771 • Fax: 815-389-2582
www.warnerelectric.com
An Altra Industrial Motion Company