

Industrial Brakes

Stromag Drum Brakes

with Electrohydraulic Thrustor

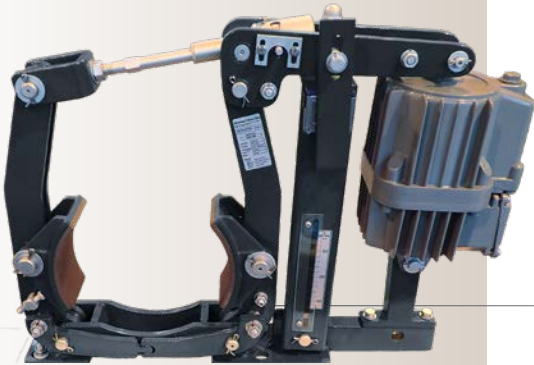

Service Brake Fitted with Electrohydraulic Thrustor

Protected against adverse environmental effects in their respective applications, Series SDB have precisely tuned safety functions. In hoisting and travelling drives, our SDB keep construction machinery safely in place and retain the rotary drives in required position, precisely.

The brake permits easy adjustment of the braking torque with a precise scale control. Our brake carries asbestos free lining pads and offers further additional options on demand.

Applications

- Mining & Cement
- Hydro Power
- Oil & Gas
- Harbour & Shipping
- Steel
- Power

Benefits include

- Maintenance free, self lubricated bushes at main hinges and sliding joints
- Brake shoe auto-aligning device and easy to change
- Galvanized steel spindles and hinges
- Automatic wear compensation
- Glued lining pads and aluminium lightweight brake shoes according to DIN 15435
- Optimised FEA tested design for reliability
- These brakes are built as per DIN 15435 and Thrustors are built according to DIN 15430. The optional drums are built as per DIN 15431

SDB brakes

Standard **DIN 15435**

- Spring application braking
- Thrustor release
- Standard voltage 230/400 VAC 50Hz
- Protection level C4M
- Automatic lining wear compensation
- Brake shoe auto-aligning device
- Scale for torque adjustment

- Brake lever synchronization
- Aluminium shoes with non abestos organic linings
- Self lubricated bushings at main hinge points
- Galvanized steel spindles and hinges

Operating conditions

- Ambient temperature : -20°C to 50°C
- Relative humidity no higher than 90%
- IP rating: IP65

Options

- **HRL**: Manual release lever with or without stop
- **BRLS**: Switch for opening monitoring
- **LWI**: Full lining wear indicators
- **SS1**: Special Switch: Schneider XCKM 110H29
- **SS2**: Special Switch: Schmersal Z4VH335 11Z
- **AV-DV**: Thrustor delay : Ascent Valve or Descent Valve
- **SV**: Special Voltage 415V 50Hz | 500V 50Hz | 480V 60Hz
- **SW**: Steel Works (specific oil + heat resistant sealings)
- **SPA**: Special paint according to the customer

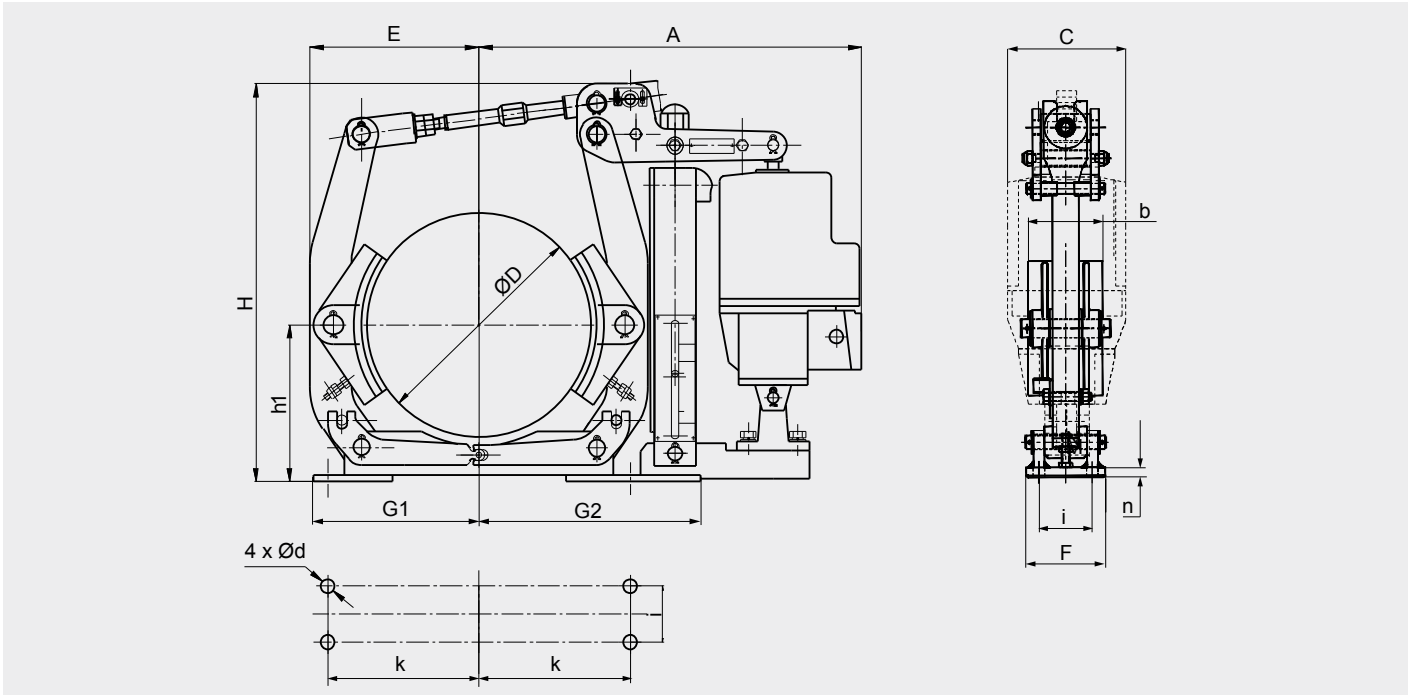

BRAKE TYPE	THRUSTOR	TORQUE (N.m.)		WEIGHT (kg)	DIMENSIONS (mm)													
		min.	max.		A	b	C	D	d	E	F	G1	G2	H	h1	i	k	n
SDB 160	TS 230/5	80	160	28	428	65	160	160	14	140	85	145	195	418	160	55	130	8
SDB 200	TS 230/5	110	260	35	470	70	160	200	14	172	90	165	255	490	160	55	145	10
	TS 300/5	140	380	38														
SDB 250	TS 230/5	140	300	45	533	90	160	250	18	202	110	200	290	583	190	65	180	12
	TS 300/5	180	380	48			195											
	TS 500/6	300	600	53			570											
SDB 315	TS 230/5	180	340	70	670	110	160	315	18	253	115	245	330	585	230	80	220	14
	TS 300/5	250	500	70			195											
	TS 500/6	315	770	75			195											
	TS 800/6	630	1200	80			195											
SDB 400	TS 500/6	400	960	138	695	140	195	400	22	310	160	310	420	715	280	100	270	14
	TS 800/6	630	1500	140			240							775				
	TS 1210/6	1000	2400	155			240							803				
SDB 500	TS 800/6	800	1920	176	925	180	240	500	22	380	180	365	535	803	340	130	325	21
	TS 1210/6	1250	3000	204										830				
	TS 2010/6	2000	4800	204										830				
SDB 630	TS 1210/6	1800	3780	310	1150	225	240	630	27	465	220	450	600	1025	420	170	400	20
	TS 2010/6	2500	6000	310														
	TS 3010/6	4000	8500	315														
SDB 710	TS 2010/6	3150	6000	435	1180	225	240	710	27	520	240	500	630	1135	470	190	450	25
	TS 3010/6	5000	9600	441														



www.stromag.com

Stromag France SAS
 Avenue de l'Europe
 18150 La Guerche sur L'Aubois - France
 sales@stromag.com