

Form-Flex® BP & B5

Installation and Maintenance Manual

P-5015-TBW
Form 1186A



▲ WARNING: Rotating equipment must be properly guarded. It is the responsibility of the user to properly guard all rotating equipment to comply with OSHA or any applicable regulations. Failure to properly guard may contribute to severe injury should someone come in contact with the rotating parts or should the rotating part fail.

▲ WARNING: DO NOT use TB Wood's products on any primary aircraft drive or any other drive which could endanger human life should a drive component fail.



WARNING: Cancer and Reproductive Harm - www.P65Warnings.ca.gov

Proper care with installation and alignment of couplings and equipment will permit a coupling to operate to full capacity, compensate for angular misalignment, and provide very good service life.

Shafts may become misaligned as a result of many natural and unavoidable causes. Heat, vibration, bearing wear, settling of foundations, etc., all tend to alter initial alignment. To ensure long life re-check alignment after a short period of actual equipment running time.

In general, coupling life is increased when shafts are initially aligned carefully. If this is not done and torque or other forces heavily stress a coupling, it will have little reserve left in which to accommodate misalignment stresses, and might not provide the length of service intended. The closer the alignment T.I.R. is to zero the better the service life of the coupling.

INSTALLATION

Preparation

Inspect the shafts and hubs and make sure they are clean and free from burrs. If the bore is straight, measure the bore and shaft to ensure a proper fit. Check for the proper fit of the keys to the shafts and hubs. If the bore is tapered, check for a good contact pattern.

Straight Bored Hubs

Coupling hubs are normally bored for an interference fit according to AGMA Standard 9002-AB6, unless otherwise specified. If the hub was specified with a clearance fit and set screws are used, install the coupling hubs so that they are in the correct position and tighten the set screw(s). If the hub is bored for an interference fit, the hub should be heated to expand the bore until it is sufficiently larger than the shaft. A hub temperature of approximately 300°F is sufficient for most interference fits. **NEVER EXCEED 600°F. DO NOT SPOT HEAT THE HUB AS IT MAY CAUSE DISTORTION.** After hub has been heated a sufficient amount, quickly position on the hub onto the shaft to the desired axial location. Hold the hub in place as it cools.

Taper Bored Hubs

Carefully mount the hub on the shaft without key(s), O-ring and back-up rings (if applicable), and tap lightly with a soft mallet to establish a metal to metal fit. This is the initial position for starting the hub advance. Measure this position, shaft end to hub flange face, with a depth gauge and record the value. Hub draw must be monitored during installation. This may be done using a dial indicator or by use of a shaft stop ring. The method of monitoring the hub draw must be established prior to removing the hub after the initial starting position has been determined. Draw the hub on the shaft the required distance to achieve the level of interference desired. Heat may be required to achieve the proper fill. **DO NOT SPOT HEAT THE HUB AS IT MAY CAUSE DISTORTION.** The amount of hub draw is dependent upon the taper angle, level of required interference, and bore diameter. Install the shaft-retaining device provided with the shaft to hold the hub.

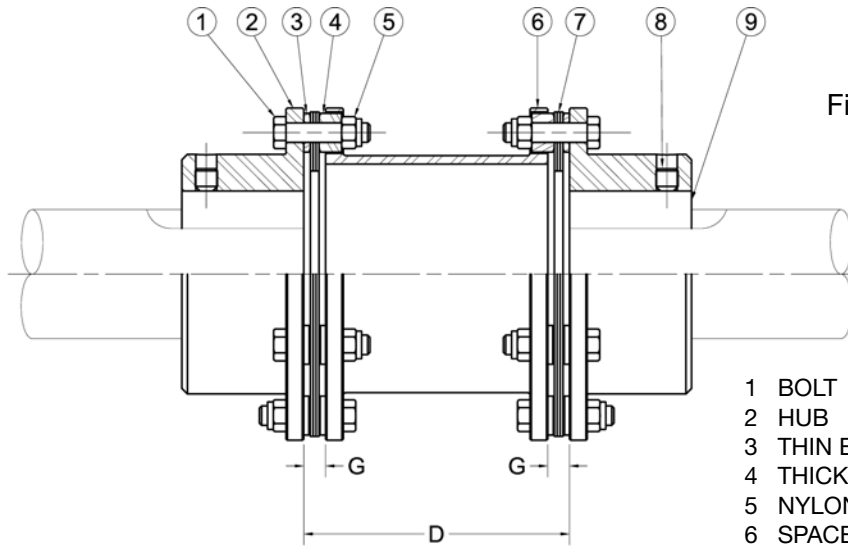

Figure 1

PARTS LIST		QTY.
1	BOLT	12
2	HUB	2
3	THIN ELEMENT WASHER	12
4	THICK ELEMENT WASHER	12
5	NYLON LOCKING UNIT	12
6	SPACER	1
7	FLEX DISCS	2
8	SET SCREW	4
9	KEY (NOT INCLUDED)	2

Spacer Sub-Assembly

1. Move the equipment to be connected into position. Set the gap between the hub faces to the required distance between shaft ends, “D” dimension in Figure 1. Set the average gap between flanges to the “G” dimension shown in Table 1 for the proper size coupling.

TABLE 1 - FLANGE TO FLANGE, DIMENSION “G” - INCHES

Size	33	38	43	48	53	58	63	68
G	.285	.335	.465	.495	.520	.555	.600	.849
±	.010	.010	.010	.010	.010	.015	.015	.015

2. Assemble the flex discs to the spacer as shown in Figure 2. Ensure that the beveled part of the washer is against the flex disc. Tighten the nylon locking nuts shown in Figure 2 to the proper torque value as indicated in Table 2 for the respective size coupling.

NOTE: The flex disc are designed for a specific thickness and are not to be used for axial adjustments.

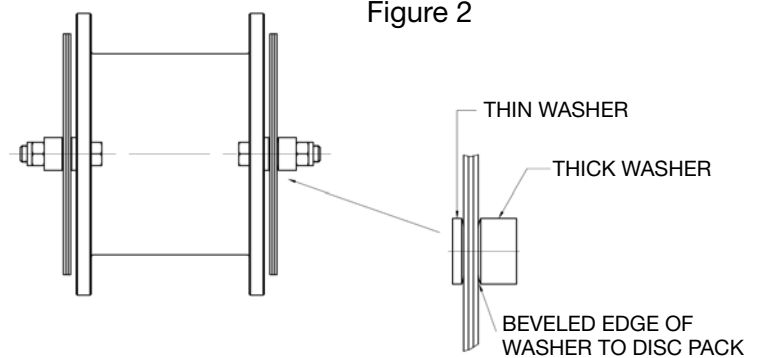

Figure 2

3. Bring the equipment into an approximate good alignment by attaching one end of the spacer to the equipment via a hub. Be sure the spacer assembly is fully supported at this time. Damage to the connected disc packs may result if the spacer is not fully supported.

Assemble the spacer to the hub via the same method as Item 2 (see figure 2 for reference). Secure the bolts with the nylon locking nuts and tighten to the proper torque value shown in Table 2 for the respective size coupling.

4. With one end of the coupling attached, align the two pieces of equipment well enough to assemble the opposite end of the spacer to its hub in the same manner as above.

TABLE 2 - NUT TIGHTENING TORQUE (LIGHTLY OILED THREADS ON STAINLESS FASTENERS)

Size	33	38	43	48	53	58	63	68
FT.LB.	8	17	40	40	60	120	120	200

ALIGNMENT

1. Attach a dial indicator to each hub. Indicate a point on the nearest spacer flange face as shown in Figure 3. Any method may be used to attach the dial indicator to the hub as long as it is firmly attached.
2. Rotate the coupling 360° to locate the minimum reading on the dial, then rotate the body or face of the indicator so that the zero reading lines up with the pointer.
3. Rotate the coupling 360° while watching the indicator for misalignment readings. The driver and driven equipment will be aligned when the maximum indicator readings are within the allowable limits as shown in Table 3. Adjust the equipment as necessary to comply with the limits.

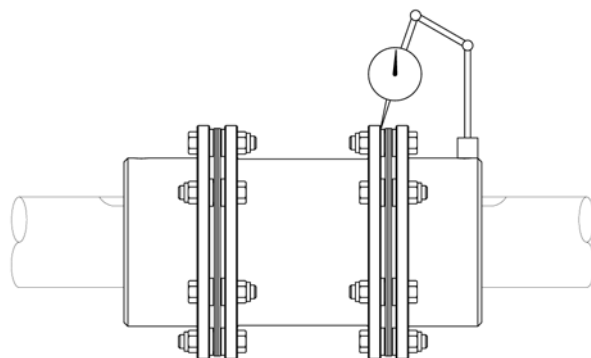

Figure 3

4. Repeat this method for the other end of the coupling.
 Note: When the equipment is properly aligned, it is advisable to dowel a right angle gearbox to its base. It has been found from experience that right angle gearboxes tend to creep in a counter rotational direction. Re-check alignment after doweling.
5. With equipment aligned and coupling assembled, make sure all bolts and washers are in their proper orientation. As stated previously, the beveled part of the washer must be against the flex discs as shown in Figure 2.

IMPORTANT: To ensure long life, re-check alignment after a short period (one to two hours) of actual equipment running time. At this time also re-torque the nylon locking nuts to the values shown in Table 3.

TABLE 3 - TOTAL INDICATOR READING, MAXIMUM; INCHES

SIZE	33	38	43	48	53	58	63	68
T.I.R.*	.024	.030	.034	.039	.04	.046	.052	.056

* Equivalent to .3° per flex element. Lower T.I.R. readings will provide better alignment of shafts and longer service life.

NOTE: The closer to zero misalignment the better the service that can be expected.

REPAIR PARTS

Repair Kit contains:
 All Hardware and 1 Flex Disc Pack
 (2 required per coupling)

Flex Disc Kit contains:
 1 Flex Disc Pack
 (2 required per coupling)

SIZE	REPAIR KIT PART #	FLEX DISC PART #
33	B033RKA	B0334101
38	B038RKA	B0384101
43	B043RKA	B434101
48	B048RKA	B0484101
53	B053RKA	B0534101
58	B058RKA	B0584101
63	B063RKA	B0634101
68	B068RKA	B0684101

⚠ WARNING ROTATING EQUIPMENT IS POTENTIALLY DANGEROUS AND MUST BE PROPERLY GUARDED. THE USER SHOULD COMPLY WITH APPLICABLE SAFETY CODES IN ACCORDANCE TO OSHA STANDARDS.

Notes

TB Wood's Facilities

North America

USA

440 North Fifth Avenue
Chambersburg, PA 17201 - USA
888-829-6637 * 717-264-7161
Belted Drives and Elastomeric Couplings

Customer Service
1-888-829-6637 (Press #5)

For Application Support
1-888-829-6637 (Press #7)

2000 Clovis Barker Road
San Marcos, TX 78666 - USA
1-888-449-9439
General Purpose Disc Couplings

Customer Service
1-888-449-9439

4970 Joule St
Reno, NV 89502 - USA
775-857-1800

Canada

9779 45 Ave NW
Edmonton, AB T6E 5V8 - Canada
+1 780-439-7979

6305 Danville Road
Mississauga, ON L5T 2H7 - Canada
1-800-829-6631

1073 Rue Bégin
Saint-Laurent, QC H4R 1V8 - Canada
+1 514-332-4812

Mexico

Comisión Federal de Electricidad 850,
Industrial San Luis,
San Luis, S.L.P., 78395 - Mexico
+52 444 137 1500

Europe

Merchant Drive, Hertford
Hertfordshire SG13 7BL - England
+44(0)1992 501900
Elastomeric Couplings

The Brands of Altra Industrial Motion

Couplings

Ameridrives
www.ameridrives.com

Bibby Turboflex
www.bibbyturboflex.com

Guardian Couplings
www.guardiancouplings.com

Huco
www.huco.com

Lamiflex Couplings
www.lamiflexcouplings.com

Stromag
www.stromag.com

TB Wood's
www.tbwoods.com

Linear Systems

Thomson
www.thomsonlinear.com

Warner Linear
www.warnerlinear.com

Geared Cam Limit Switches

Stromag
www.stromag.com

Engineered Bearing Assemblies

Kilian
www.kilianbearings.com

Electric Clutches & Brakes

Matrix
www.matrix-international.com

Stromag
www.stromag.com

Warner Electric
www.warnerelectric.com

Deltran
www.thomsonlinear.com

Belted Drives

TB Wood's
www.tbwoods.com

Heavy Duty Clutches & Brakes

Twiflex
www.twiflex.com

Stromag
www.stromag.com

Svendborg Brakes
www.svendborg-brakes.com

Wichita Clutch
www.wichitaclutch.com

Gearing & Specialty Components

Bauer Gear Motor
www.bauergears.com

Boston Gear
www.bostongear.com

Delevan
www.delevan.com

Delroyd Worm Gear
www.delroyd.com

Nuttall Gear
www.nuttallgear.com

Engine Braking Systems

Jacobs Vehicle Systems
www.jacobsvehiclesystems.com

Precision Motors & Automation

Kollmorgen
www.kollmorgen.com

Miniature Motors

Portescap
www.portescap.com

Overrunning Clutches

Formsprag Clutch
www.formsprag.com

Marland Clutch
www.marland.com

Stieber
www.stieberclutch.com

Neither the accuracy nor completeness of the information contained in this publication is guaranteed by the company and may be subject to change in its sole discretion. The operating and performance characteristics of these products may vary depending on the application, installation, operating conditions and environmental factors. The company's terms and conditions of sale can be viewed at <http://www.altramotion.com/terms-and-conditions/sales-terms-and-conditions>. These terms and conditions apply to any person who may buy, acquire or use a product referred to herein, including any person who buys from a licensed distributor of these branded products.

©2019 by TB Wood's LLC. All rights reserved. All trademarks in this publication are the sole and exclusive property of TB Wood's LLC or one of its affiliated companies.



www.tbwoods.com

2000 Clovis Barker Road
San Marcos, TX 78666
512-353-4000